

# 5277296PCOM CARVER BAR CABINET

**A**meriwood  
HOME

Date of Purchase: \_\_\_\_/\_\_\_\_/\_\_\_\_  
Lot Number:

**B345277296PCOM01**

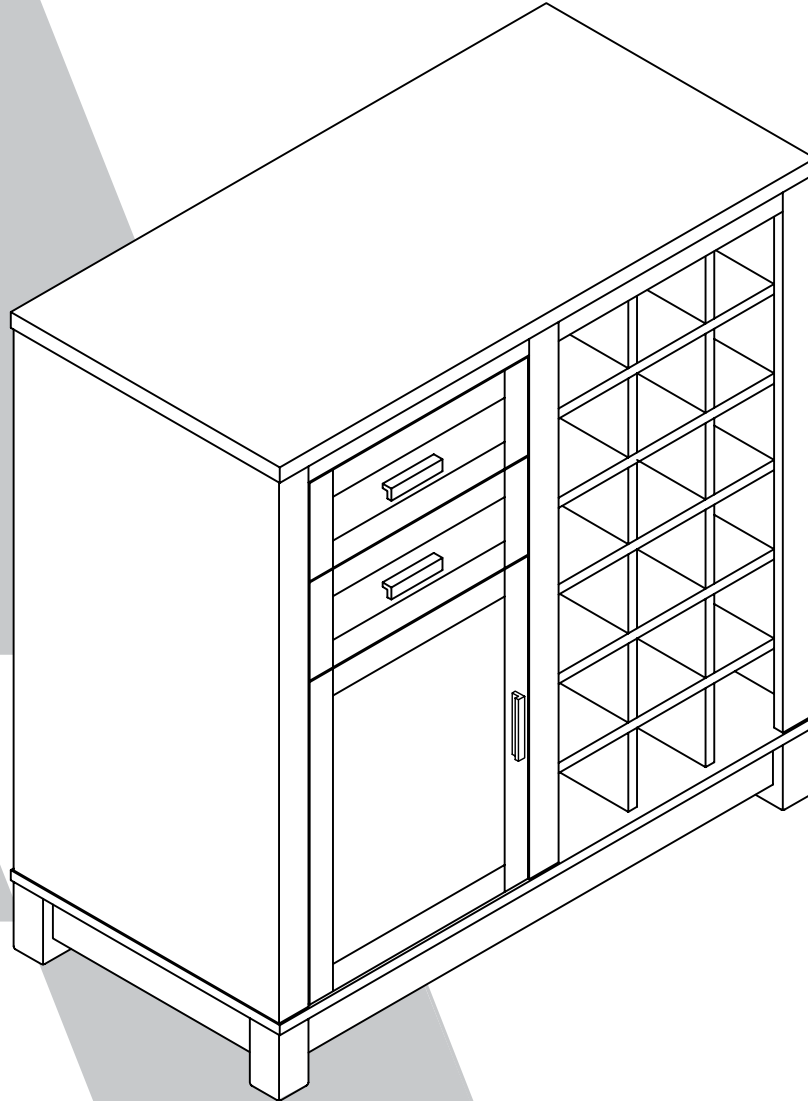

THIS INSTRUCTION BOOKLET CONTAINS **IMPORTANT** SAFETY INFORMATION. PLEASE READ AND KEEP FOR FUTURE REFERENCE.

### **Do Not Return This Product!**

Contact our customer service team for help first  
Call: 1-800-489-3351 (toll free)  
Monday-Friday 9am - 5pm CST  
Visit: [www.ameriwoodhome.com](http://www.ameriwoodhome.com)



## **WARNING**

- Unit can tip over causing severe injury or death.
- Anchor unit to stud in wall (if instructed to)
- Do not allow children climb on unit
- Put heavy items on lower shelves or drawers

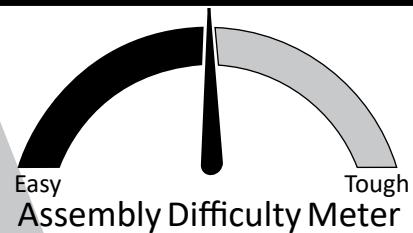

Follow Ameriwood Home



# Contact Us!

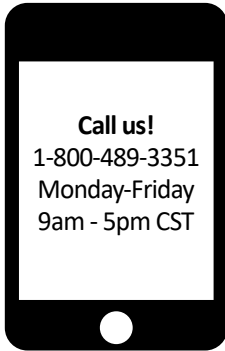

**Do NOT return this product!**  
Contact our friendly customer service team first for help

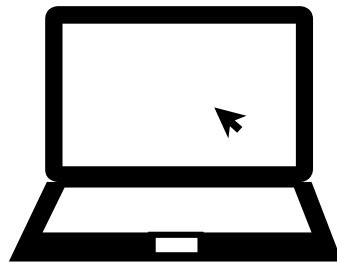

Visit [ameriwoodhome.com](http://ameriwoodhome.com)

Assembly Tips



# Helpful Hints

PEOPLE NEEDED FOR ASSEMBLY: **1-2**  
ESTIMATED ASSEMBLY TIME: **1 HOUR**

- Open your item in the area you plan to keep it for less heavy lifting
- Identify, sort and count the parts before attempting assembly
- Compression dowels are tapped in with a hammer
- Slides are labeled with a R (right) and L (left) for proper placement
- Make sure to always face the point on the top of the Cam Lock towards the outer edge
- Use all the nails provided for the back panel and spread them out equally
- Back Panel must be used to make sure your unit is sturdy
- Do NOT use harsh chemicals or abrasive cleaners on this item
- Never push, pull, or drag your furniture



# Before You Start

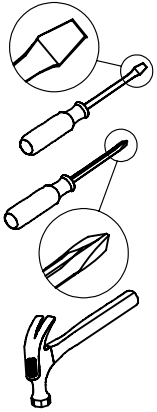
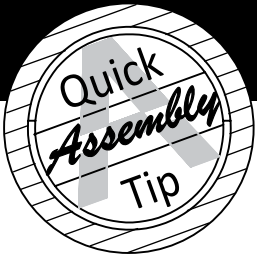

- ✓ Read through each step carefully and follow the proper order
- ✓ Separate and count all your parts and hardware
- ✓ Give yourself enough room for the assembly process
- ✓ Have the following tools: Flat Head Screwdriver, #2 Phillips Head Screwdriver and Hammer
- ✓ Caution: If using a power drill or power screwdriver for screwing, please be aware to slow down and stop when screw is tight. Failure to do so may result in stripping the screw.

# Cam Lock Fastening System

This Cam Lock Fastening System will be used throughout the assembly process.

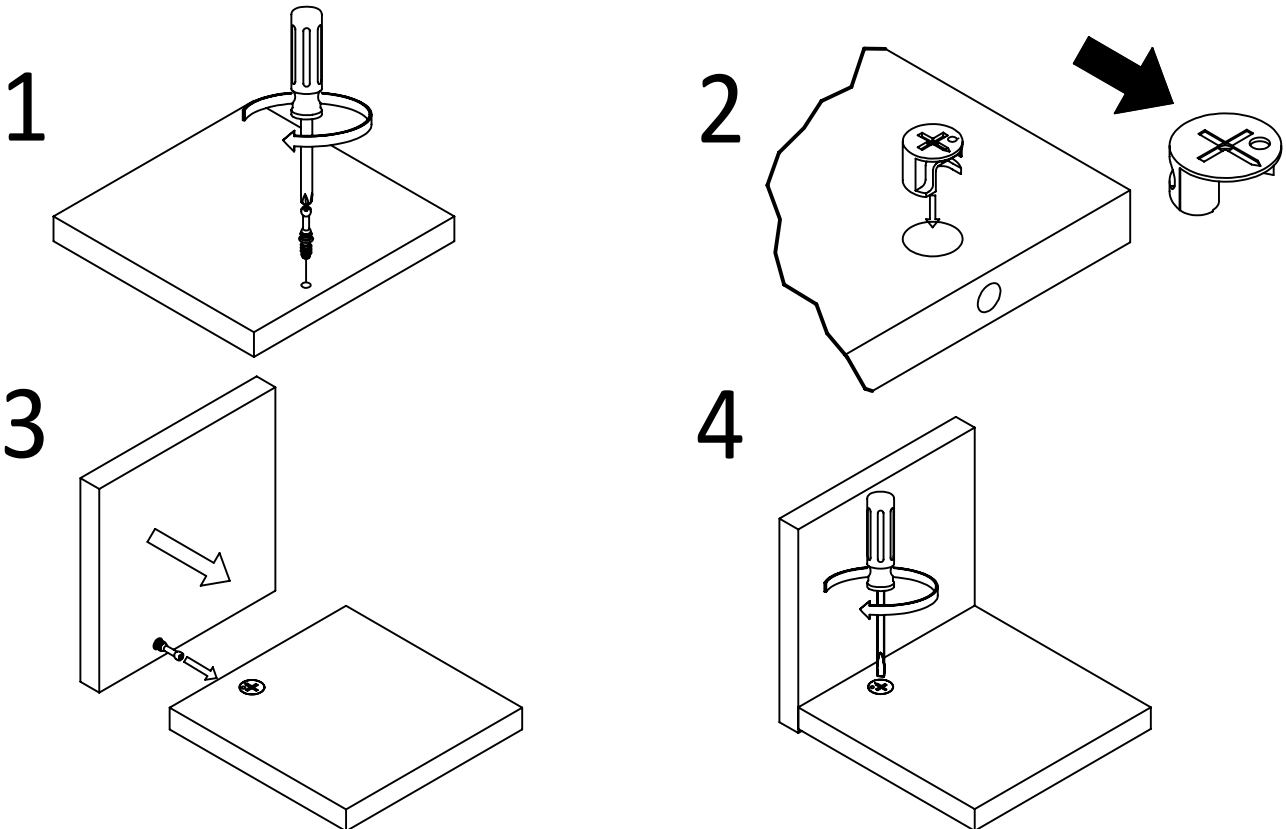

# Board Identification

Not actual size

1

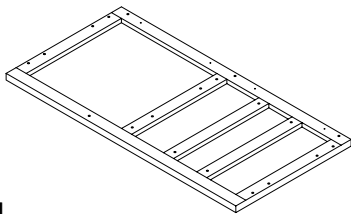

x1  
T5277296010UD  
TOP PANEL

2

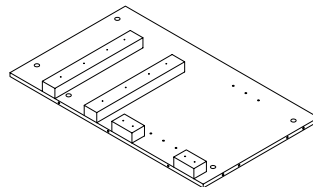

x1  
T5277296020UD  
LEFT SIDE PANEL

3

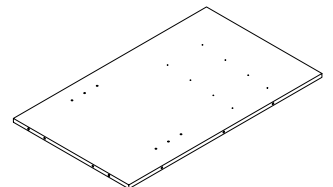

x1  
T5277296030UD  
MIDDLE PARTITION

4

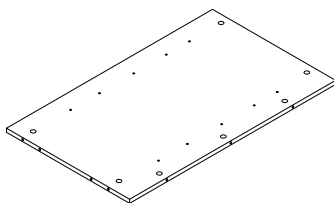

x1  
T5277296040UD  
RIGHT SIDE PANEL

5

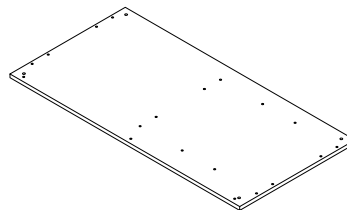

x1  
T5277296050UD  
BOTTOM PANEL

6

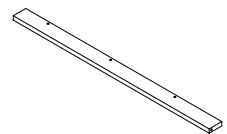

x2  
T5277296060UD  
LEFT SIDE RAIL

7

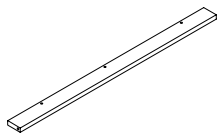

x1  
T5277296070UD  
RIGHT SIDE RAIL

8

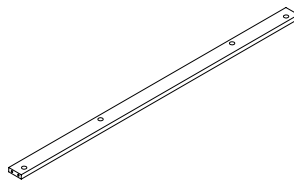

x2  
T5277296080UD  
LONG LOWER RAIL

9

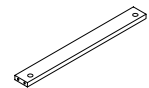

x2  
T5277296090UD  
SHORT LOWER RAIL

10



x4  
T5277296100UD  
FOOT

11

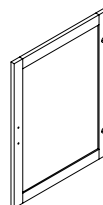

x1  
T5277296110UD  
DOOR

12

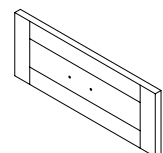

x2  
T5277296120UD  
DRAWER FRONT

# Board Identification

Not actual size

13



x2  
T5277296130UD  
LEFT DRAWER SIDE

14



x2  
T5277296140UD  
RIGHT DRAWER SIDE

15

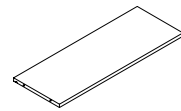

x2  
T5277296150UD  
DRAWER BACK

16

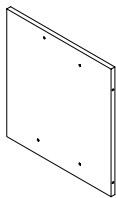

x4  
T5277296160UD  
FIXED SHELF

17

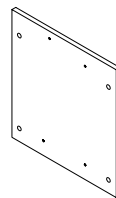

x1  
T5277296170UD  
FIXED SHELF

18



x10  
T5277296180UD  
SMALL PARTITION

19



x2  
T5277296190UD  
SMALL PARTITION

20

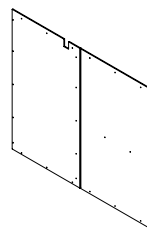

x1  
T5277296200UD  
BACK PANEL

21

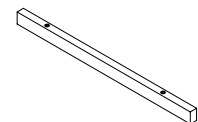

x2  
T5277296210UD  
TOP APRON

22

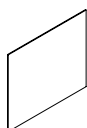

x2  
T5277296220UD  
DRAWER BOTTOM

23

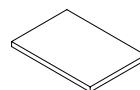

x1  
T5277296230UD  
ADJUSTABLE SHELF

# Part List

Actual Size



x45  
TUD0001  
Cam Bolt

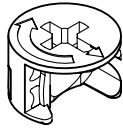

x45  
TUD0002  
Cam Lock  
15-12



x42  
TUD0030  
DOWEL 6 X 30



x20  
TUD0036  
DOWEL M6 X 50

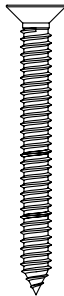

x12  
TUD0009  
CBS 4 x 38



x40  
TUD0008  
CBS 3.5 x 16

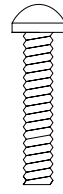

x6  
TUD0033  
PH SCREW  
M4 X 20

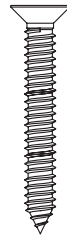

x4  
TUD0022  
CBS 4 X 30



x8  
TUD0004  
DOWEL  
M8 X 25

# Part List

Not Actual Size

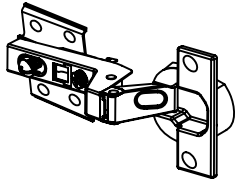

x2  
TUD0037  
HINGE Ø35

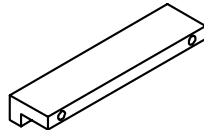

x3  
TUD0012  
HANDLE

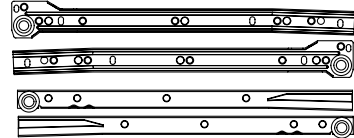

x2 SETS  
TUD0017  
DRAWER SLIDE  
350 MM



x4  
TUD0035  
SHELF SUPPORT

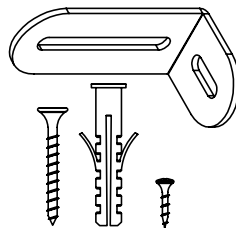

x1 set  
TUD0021  
ANTI TIPPING KIT

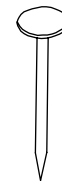

x29  
TUD0006  
NAIL

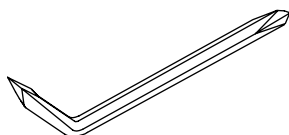

x1  
TUD0065  
HEX KEY

# Step 1

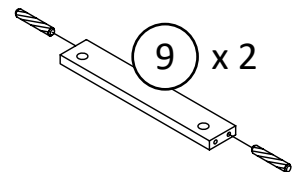
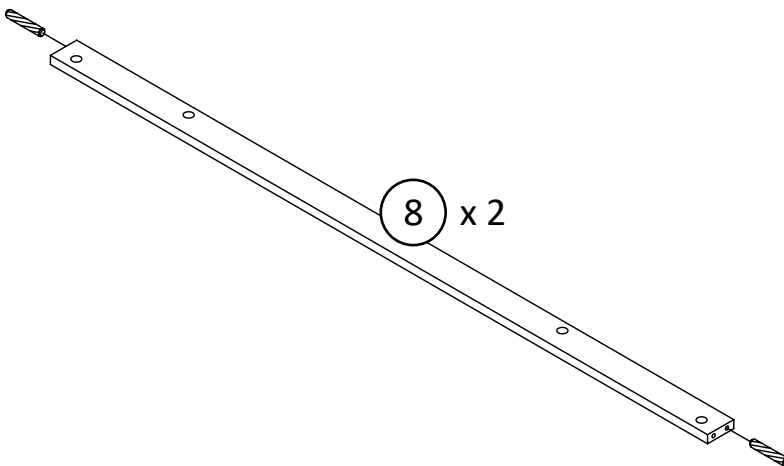
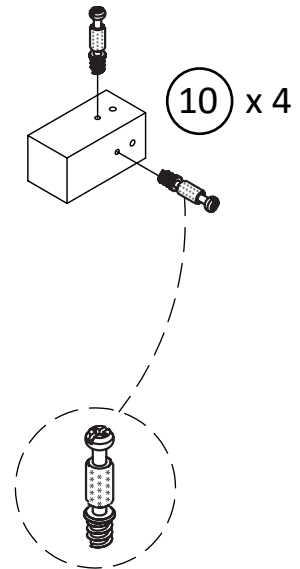
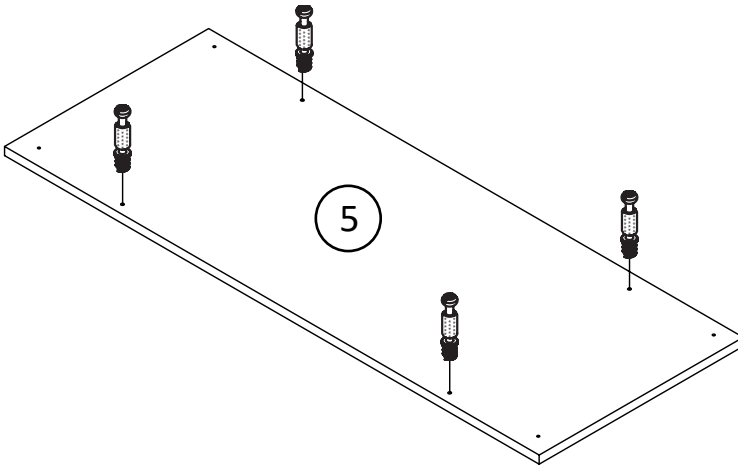
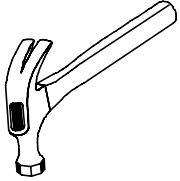
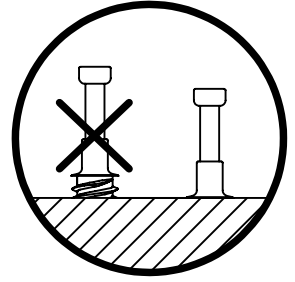
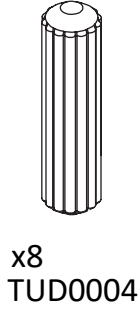
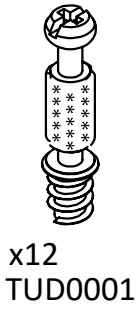
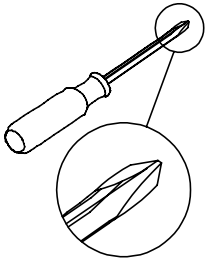

\* raw edges are shaded



# Step 2

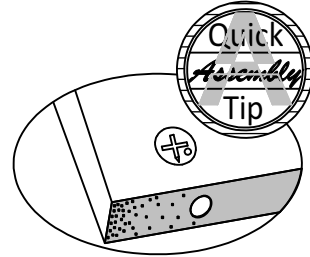
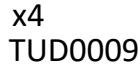
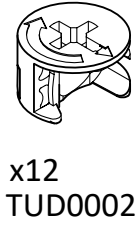
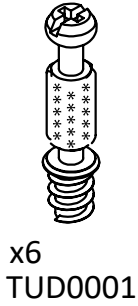
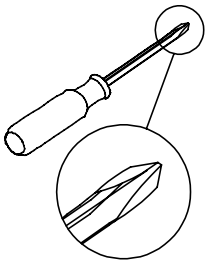

Proper orientation of CAM LOCK

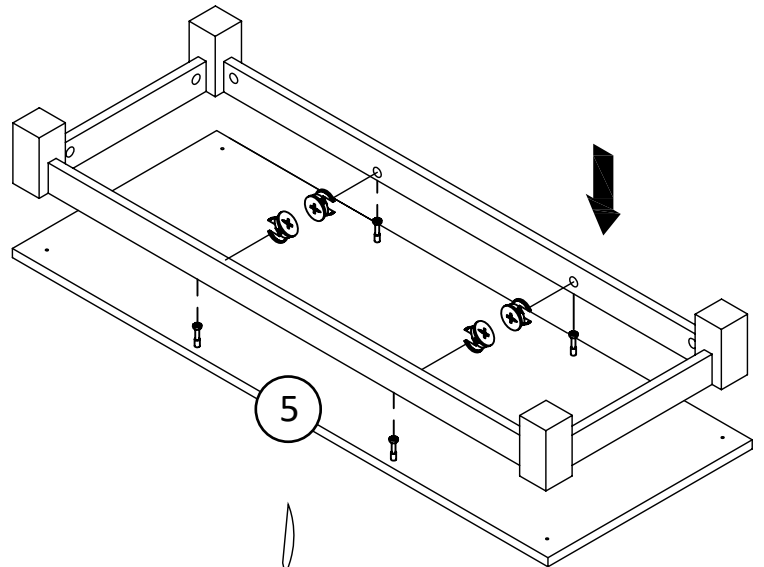
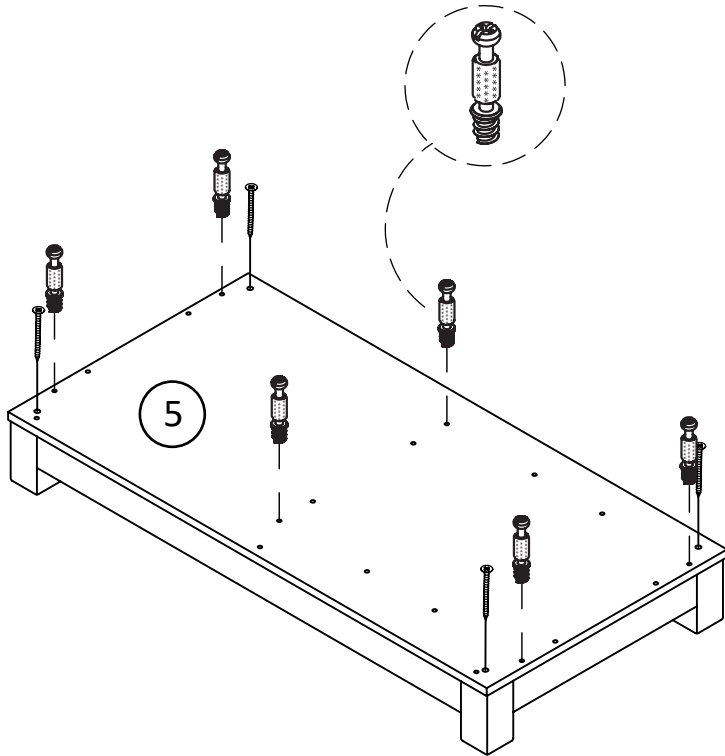
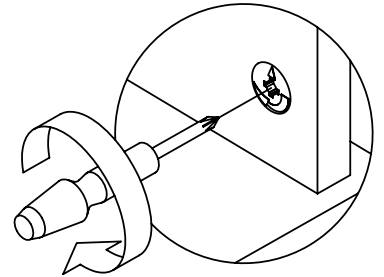
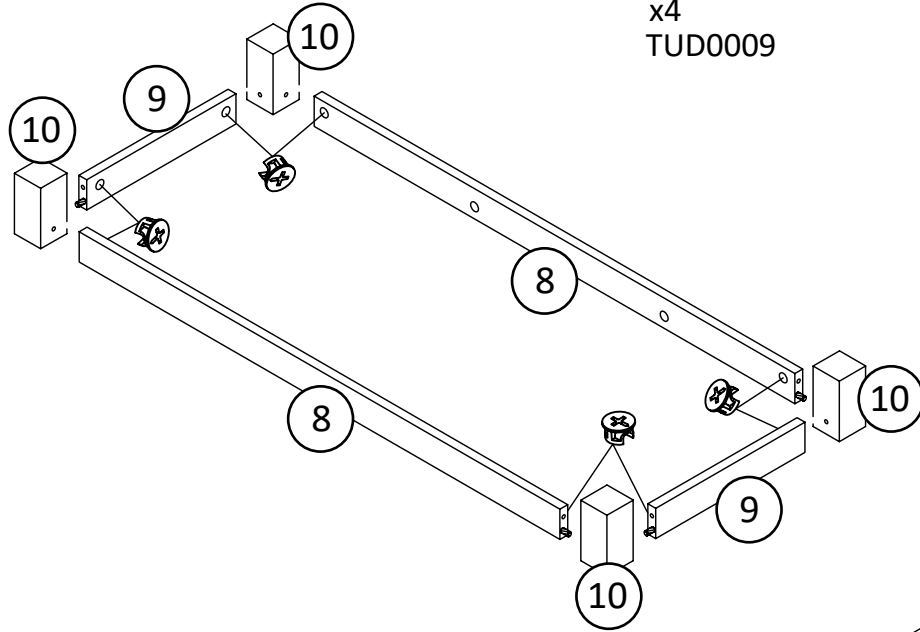
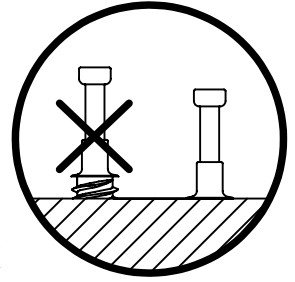

\* raw edges are shaded

# Step 3

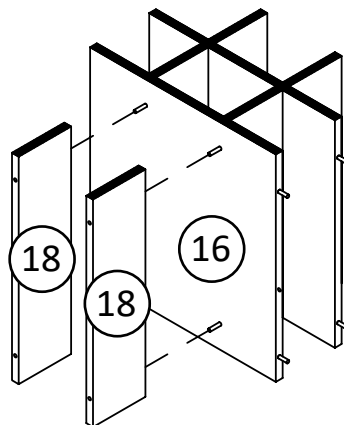
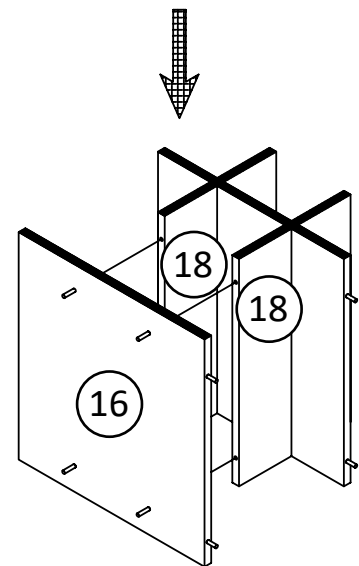
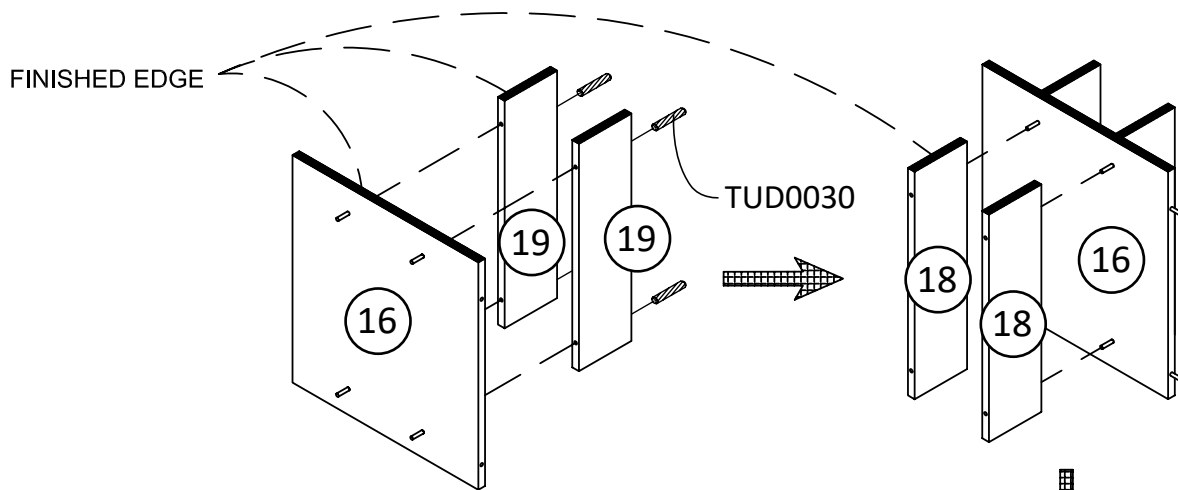
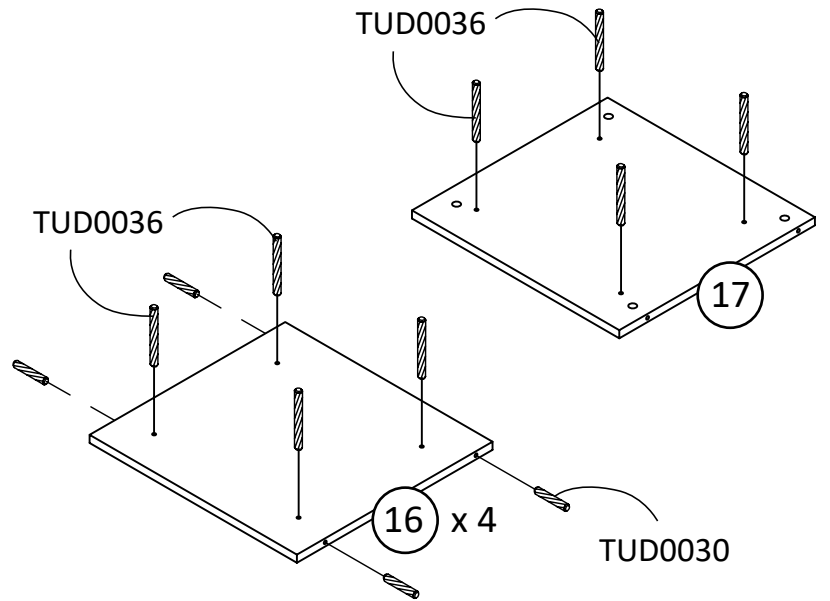
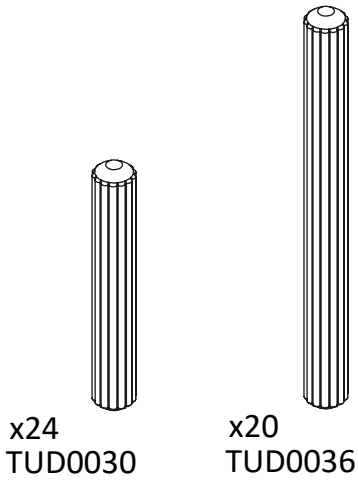
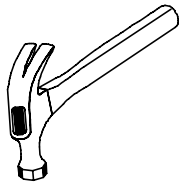

Go to step 4

\* raw edges are shaded

# Step 4

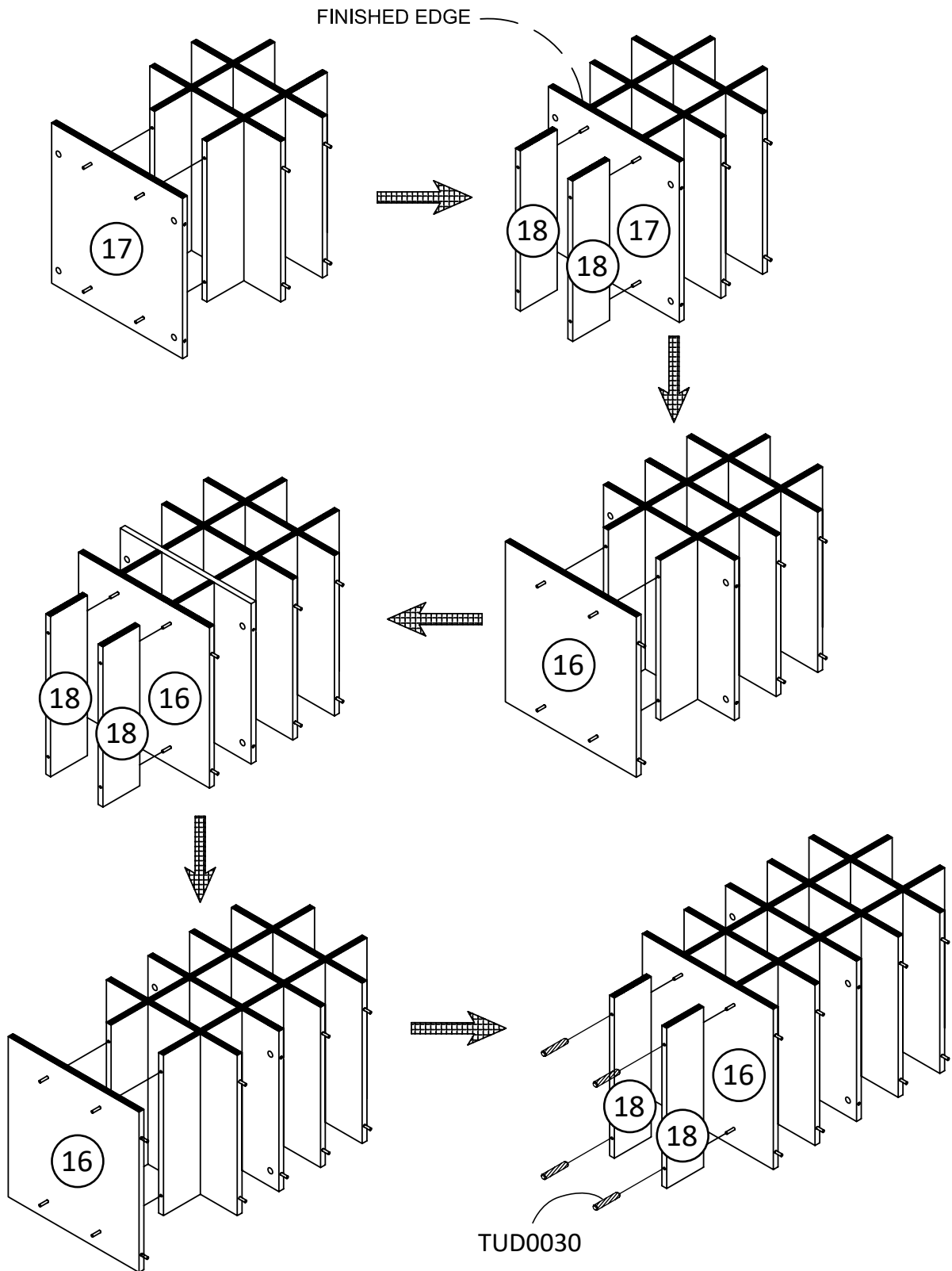
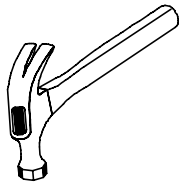

\* raw edges are shaded

# Step 5

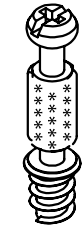
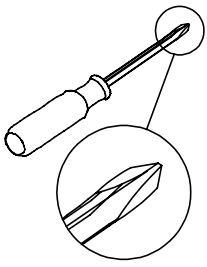

x6  
TUD0001

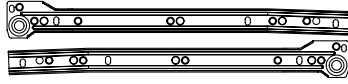

x2 SETS  
TUD0016



x16  
TUD0008



x4  
TUD0022

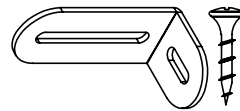
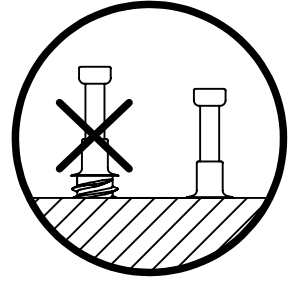

x1  
TUD0021

Do not fully tighten screw.

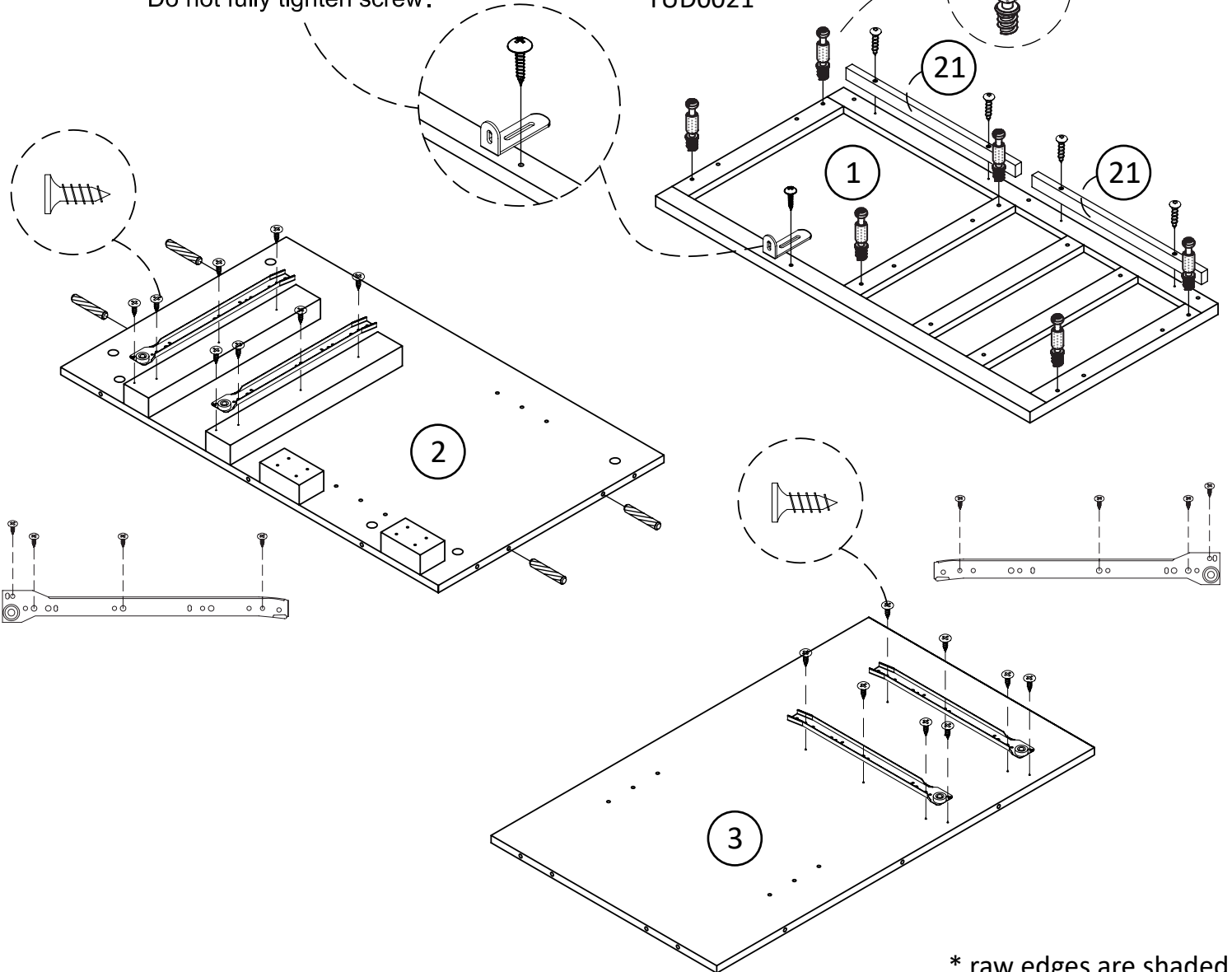

\* raw edges are shaded

# Step 6

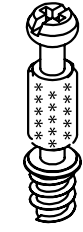
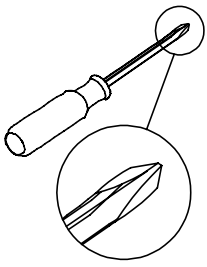

x21  
TUD0001



x14  
TUD0030

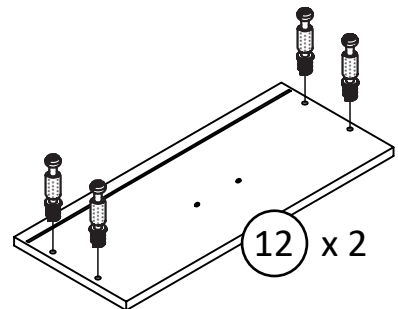
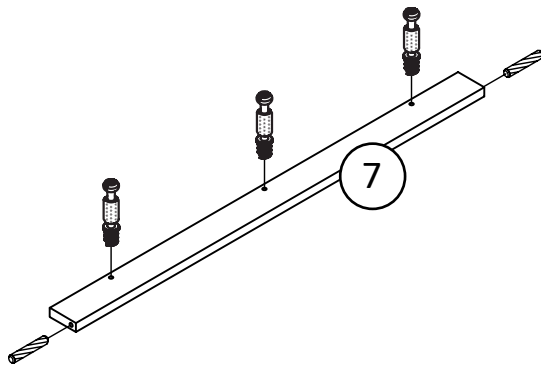
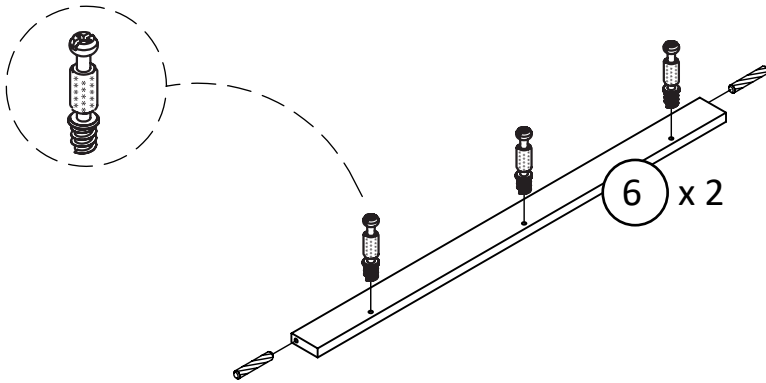
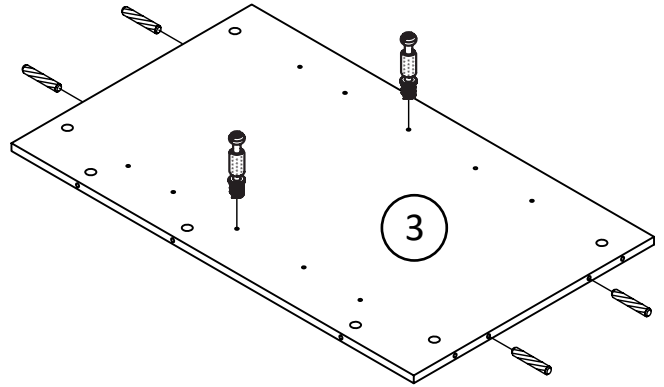
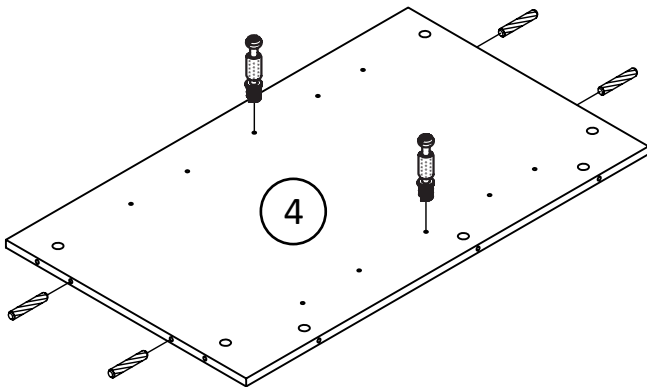
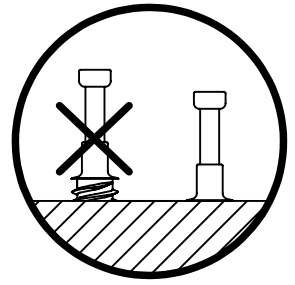

\* raw edges are shaded

# Step 7

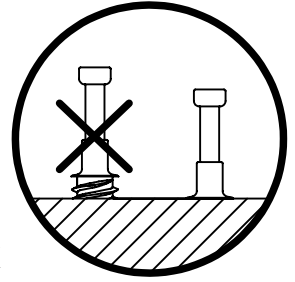
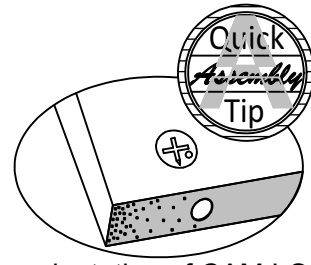
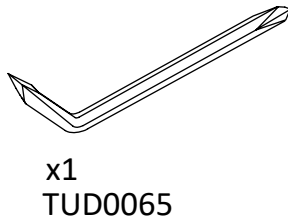
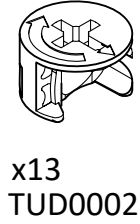
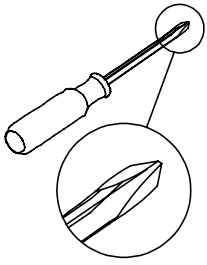

Proper orientation of CAM LOCK

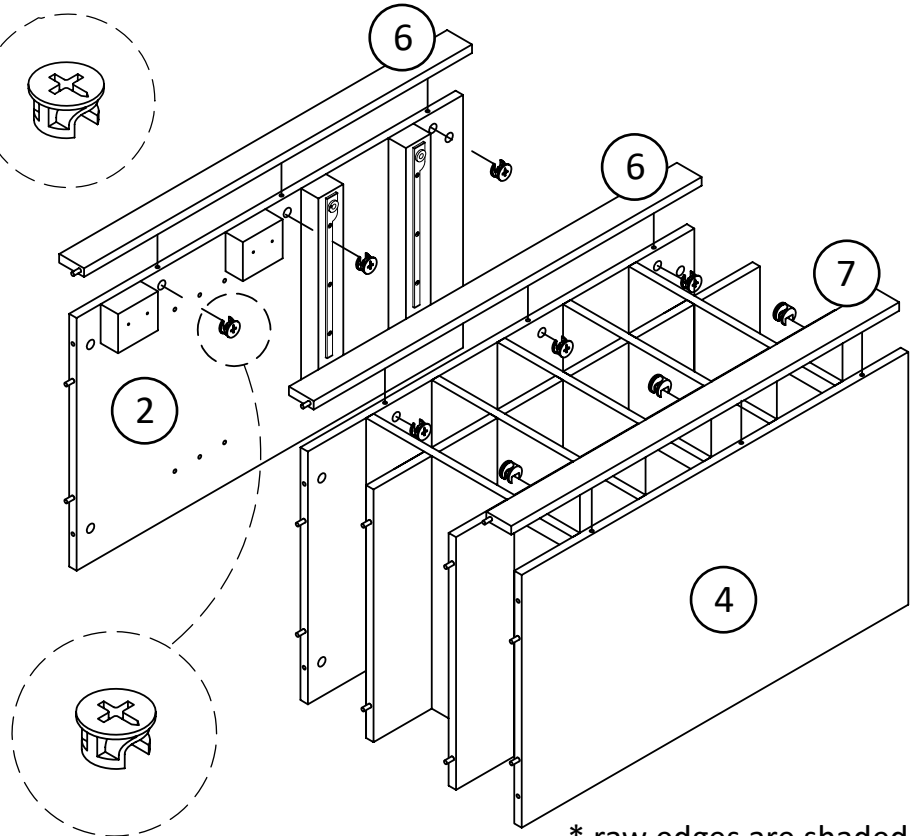
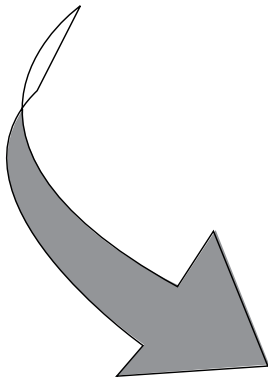
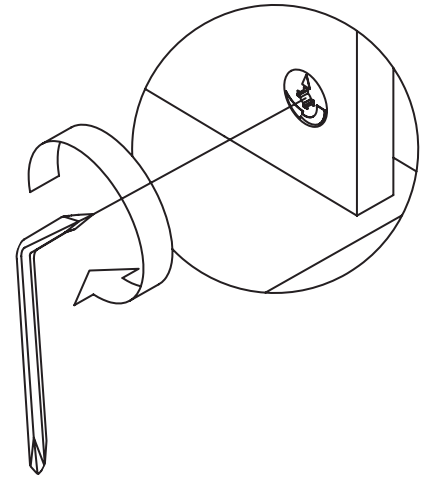
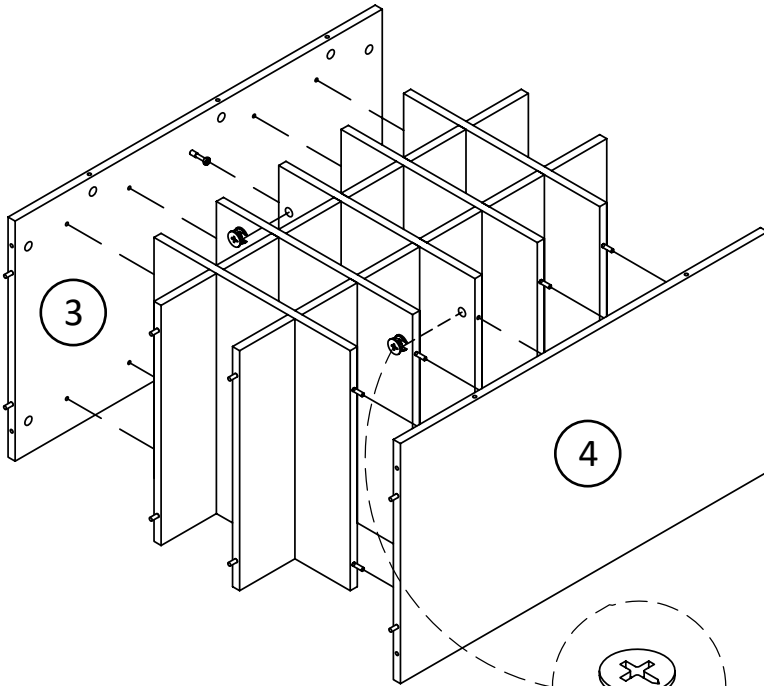

\* raw edges are shaded

# Step 8

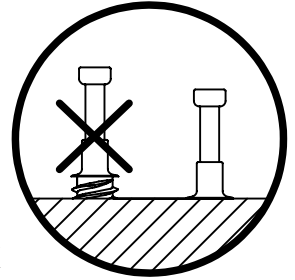
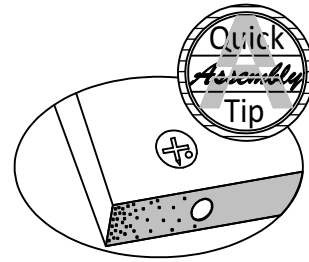
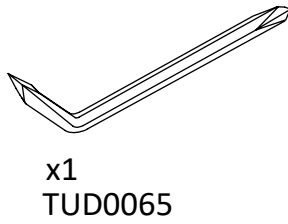
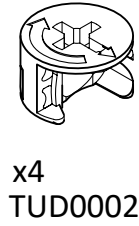
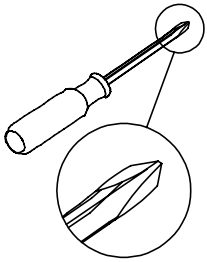

Proper orientation of CAM LOCK

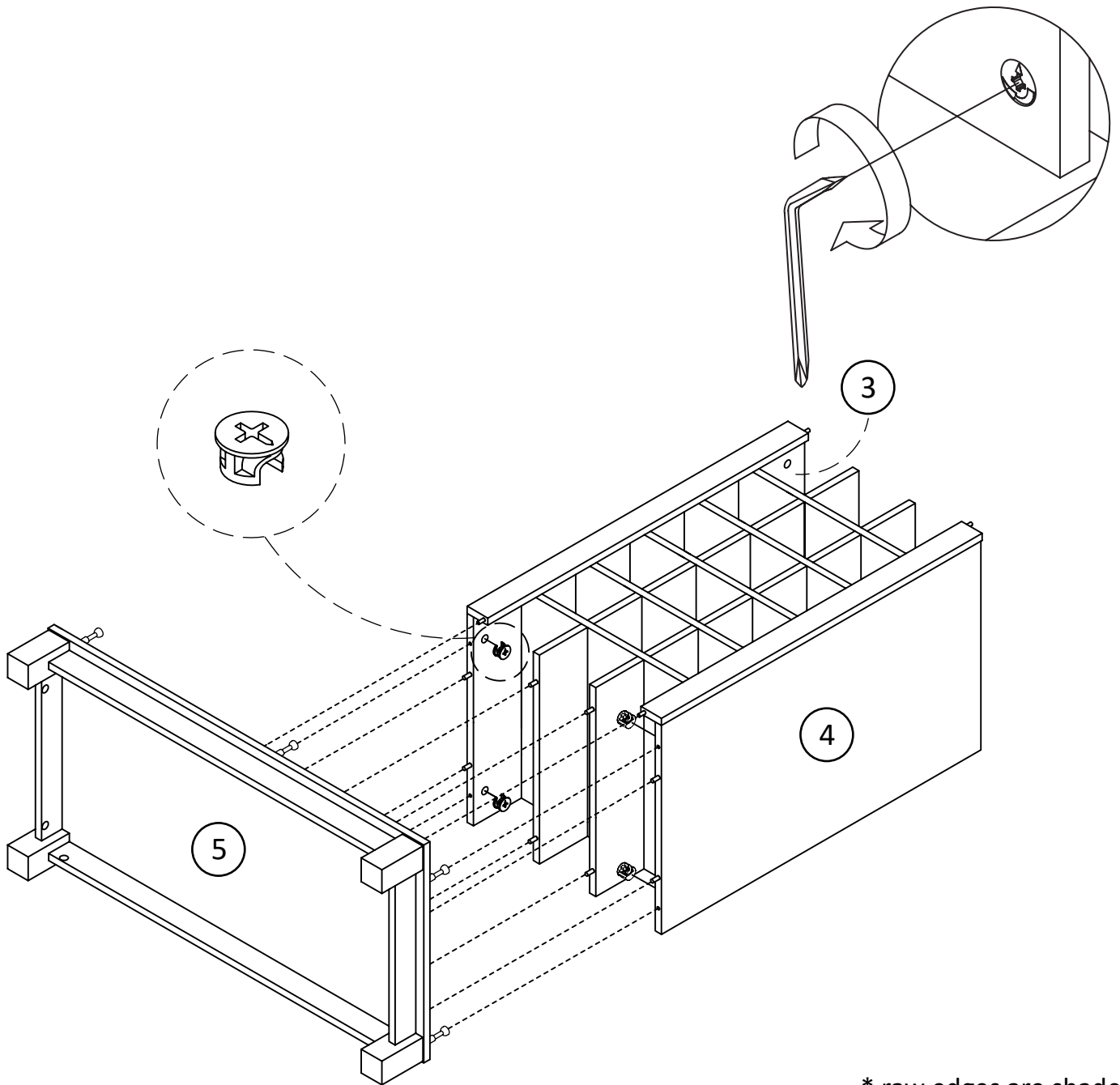

\* raw edges are shaded

# Step 9

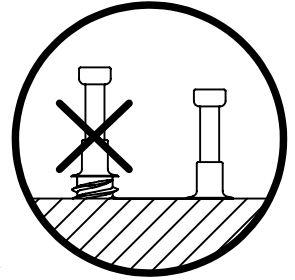
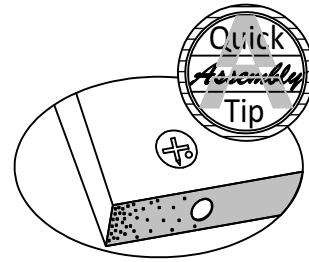
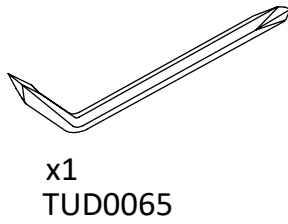
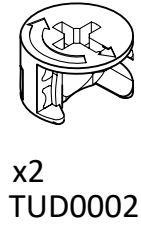
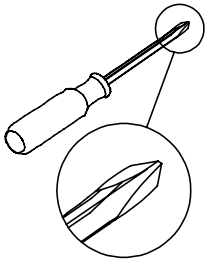

Proper orientation of CAM LOCK

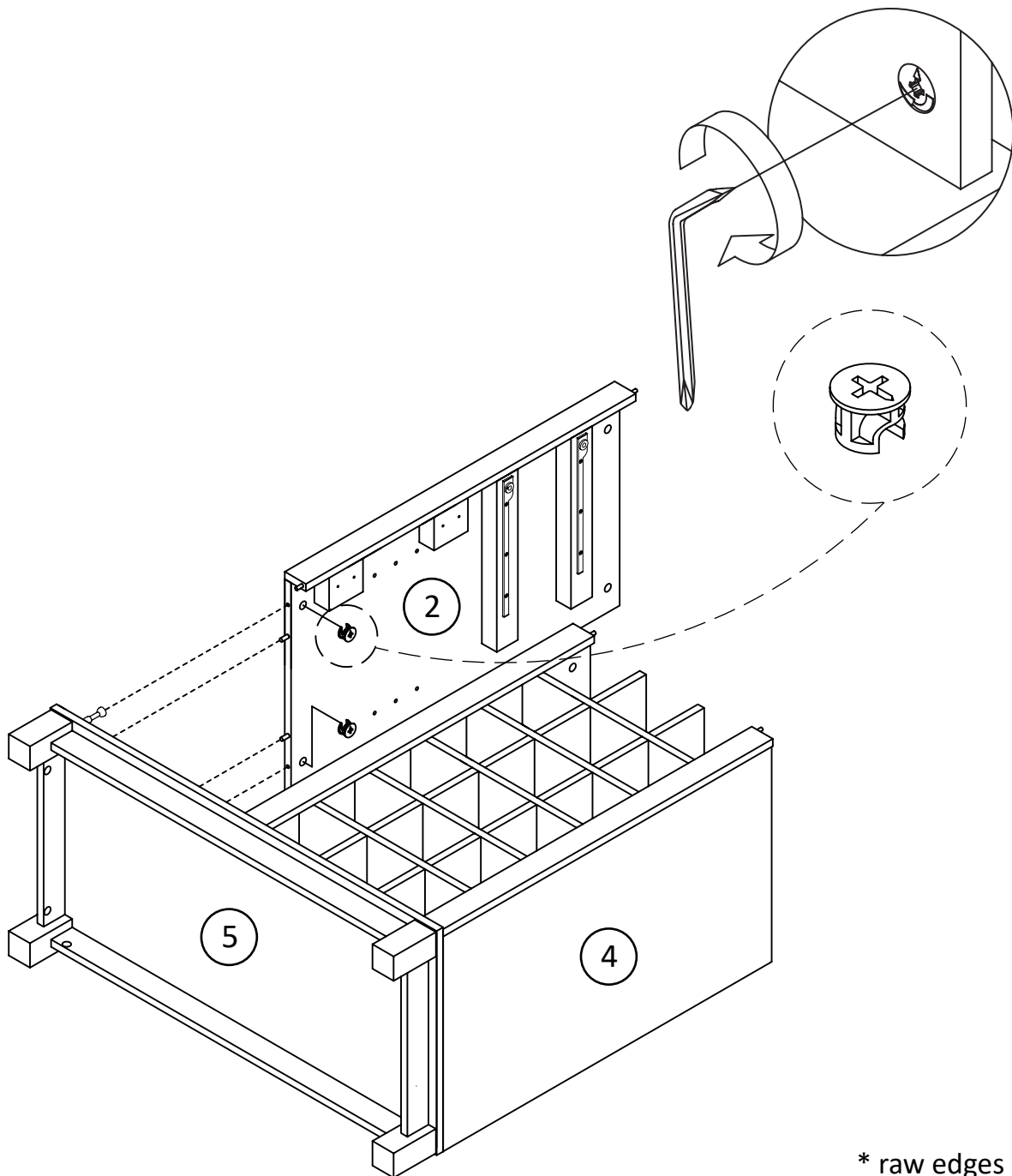

\* raw edges are shaded



# Step 10

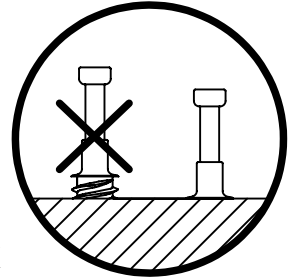
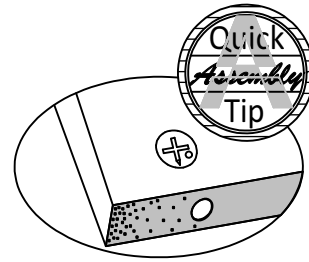
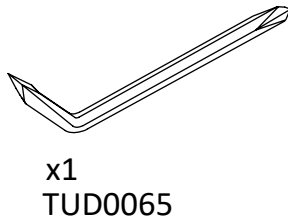
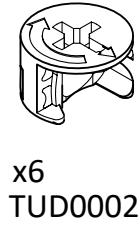
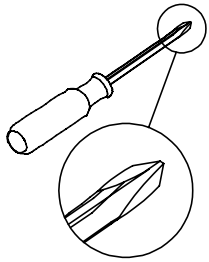

Proper orientation of CAM LOCK

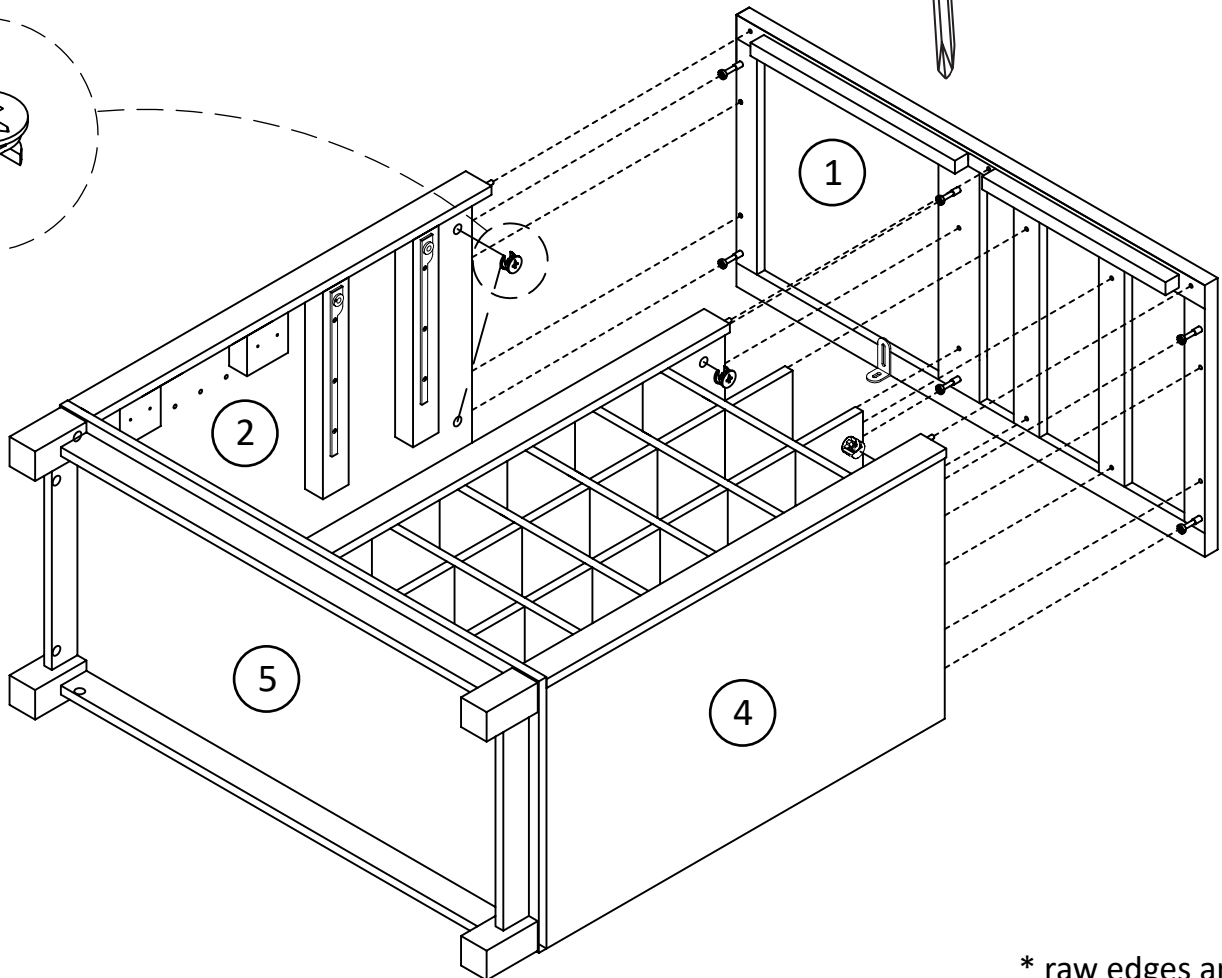
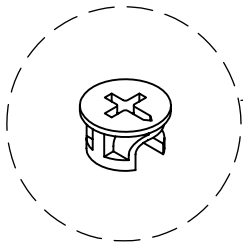
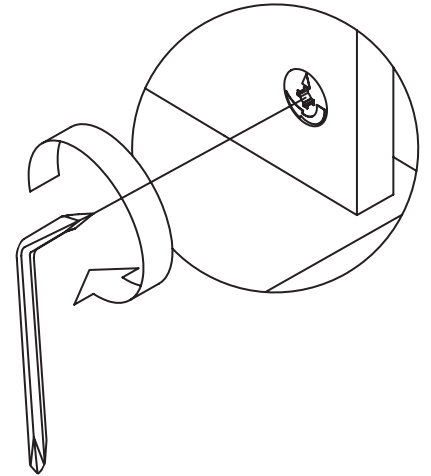

\* raw edges are shaded

# Step 11

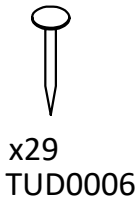
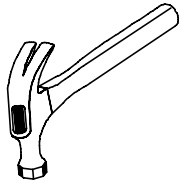

**IMPORTANT!** THE BACK PANEL IS A STRUCTURAL PART OF THIS UNIT AND MUST BE INSTALLED PROPERLY.

Attached back panel as shown nailing straight into the raw edges.  
Ensure that the unit is square.  
Distance from corner to corner must be equal as shown.

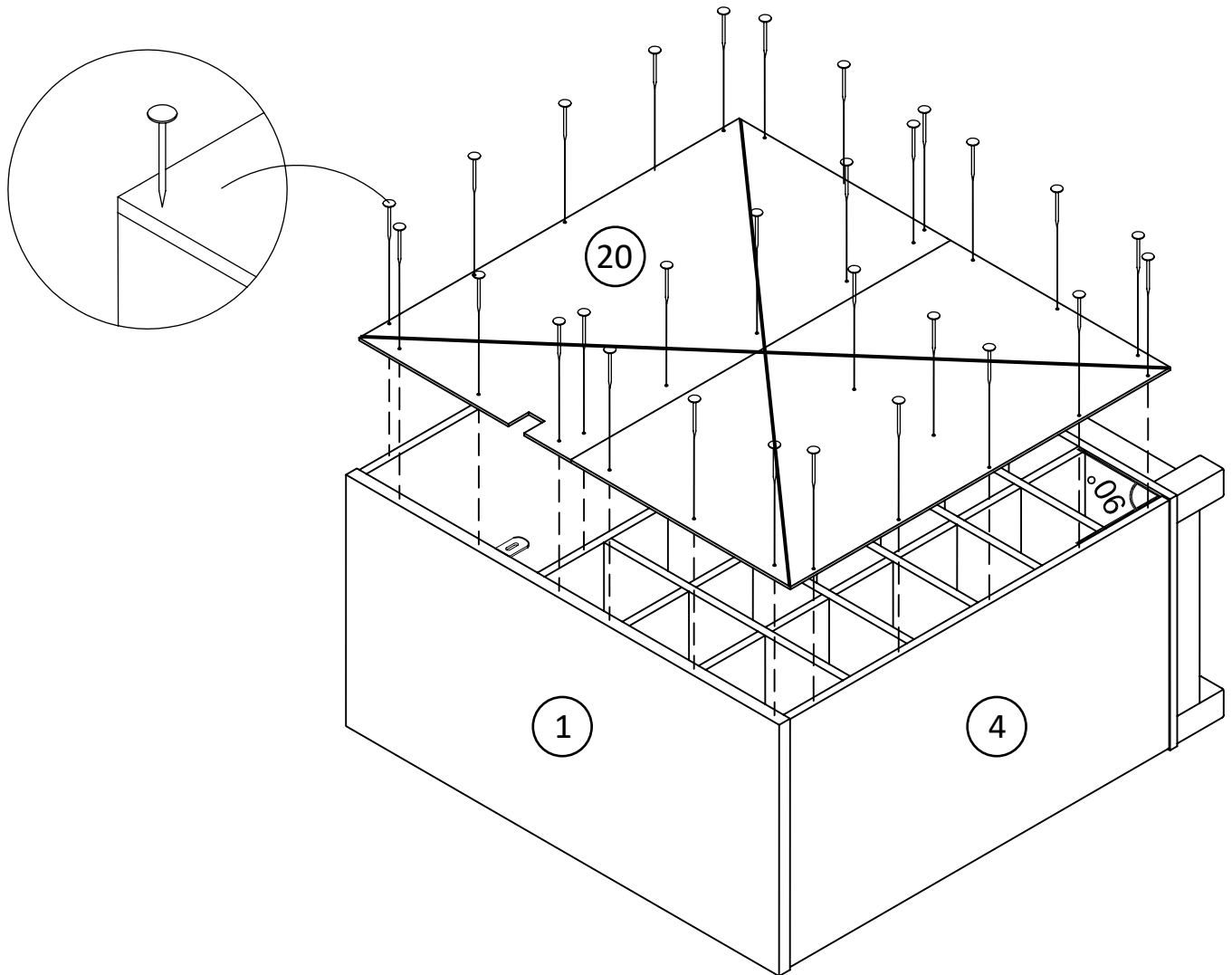

\* raw edges are shaded

# Step 12

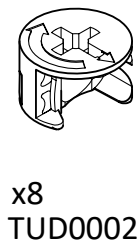
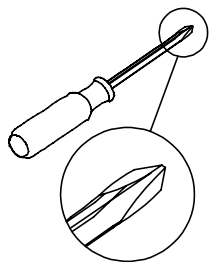

x8  
TUD0002

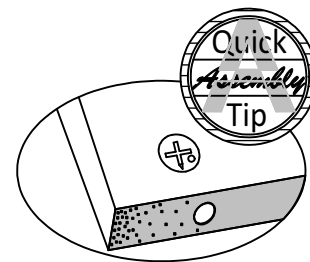

Proper orientation of CAM LOCK

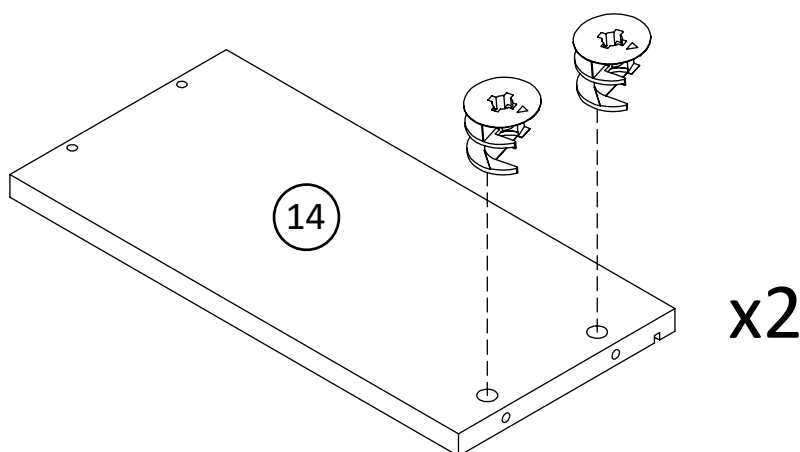
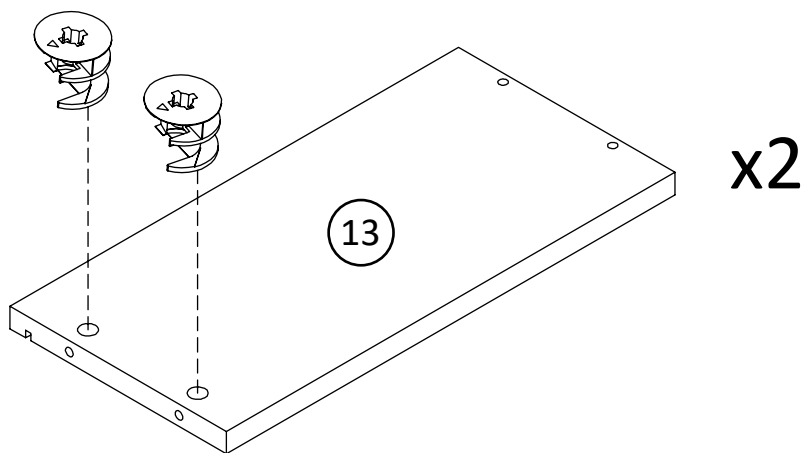

\* raw edges are shaded

# Step 13

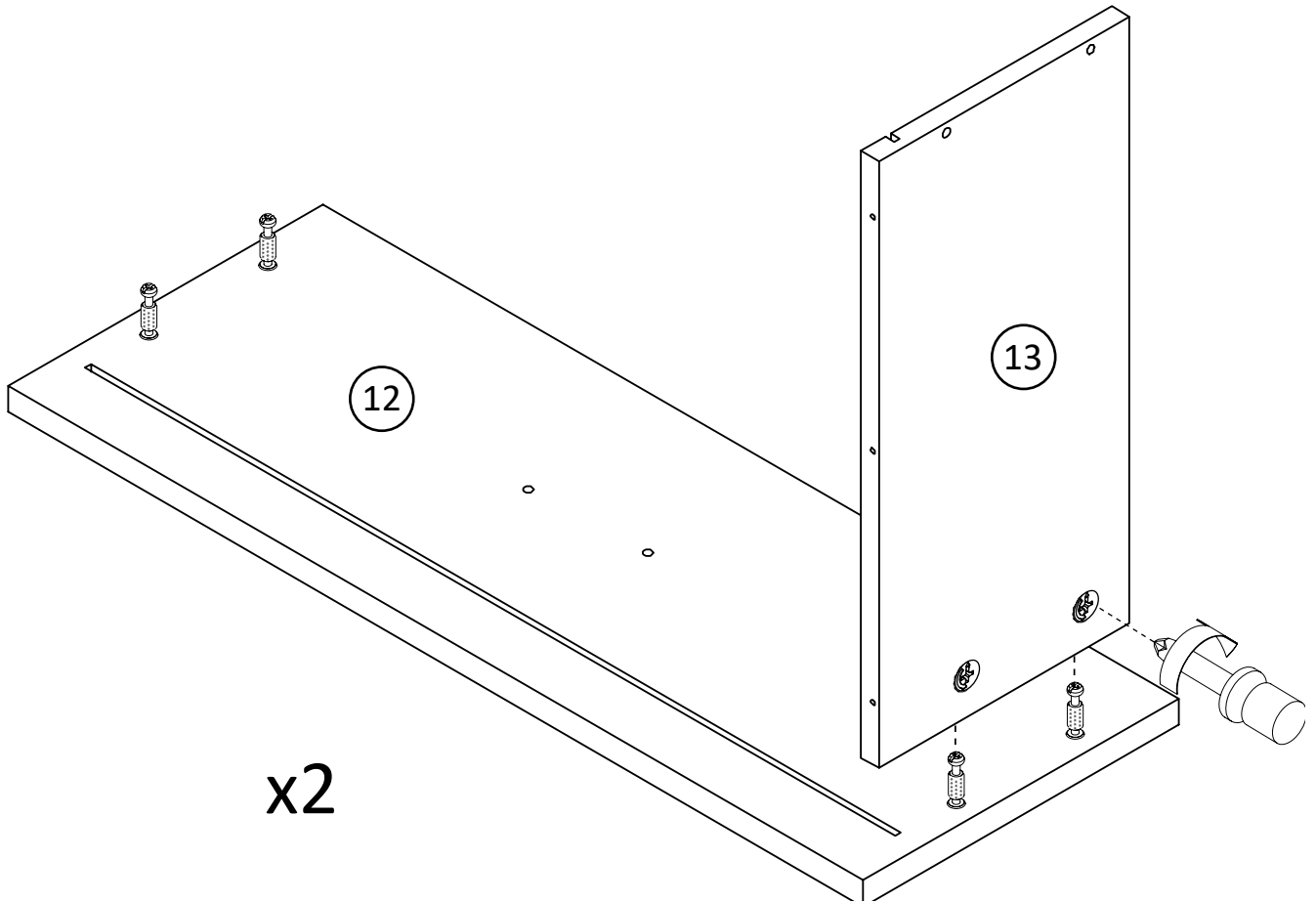
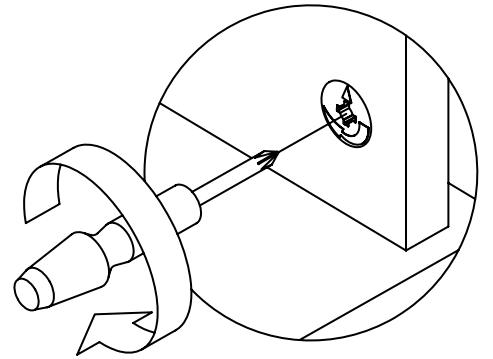
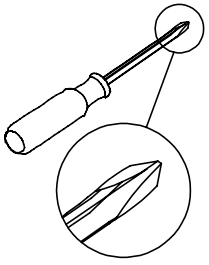

\* raw edges are shaded

# Step 14

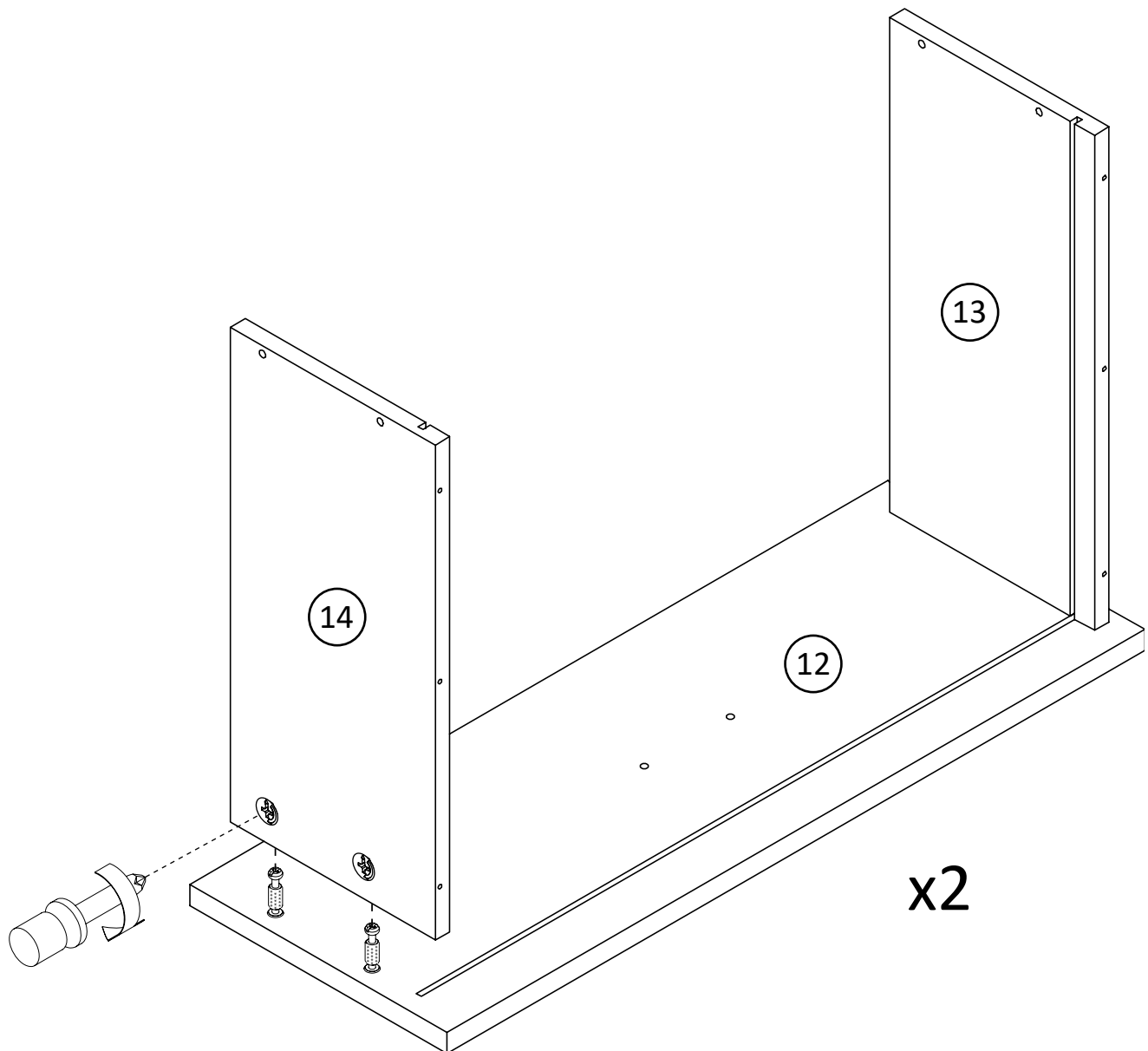
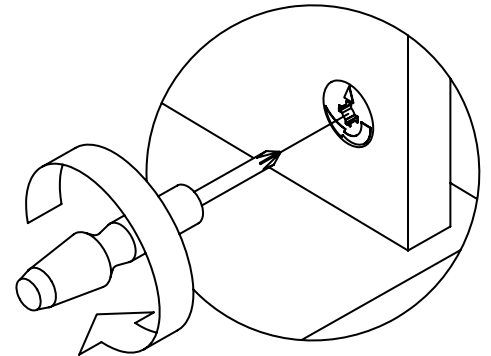
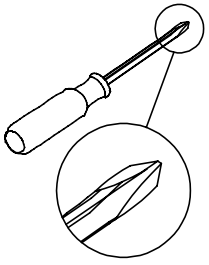

\* raw edges are shaded

# Step 15

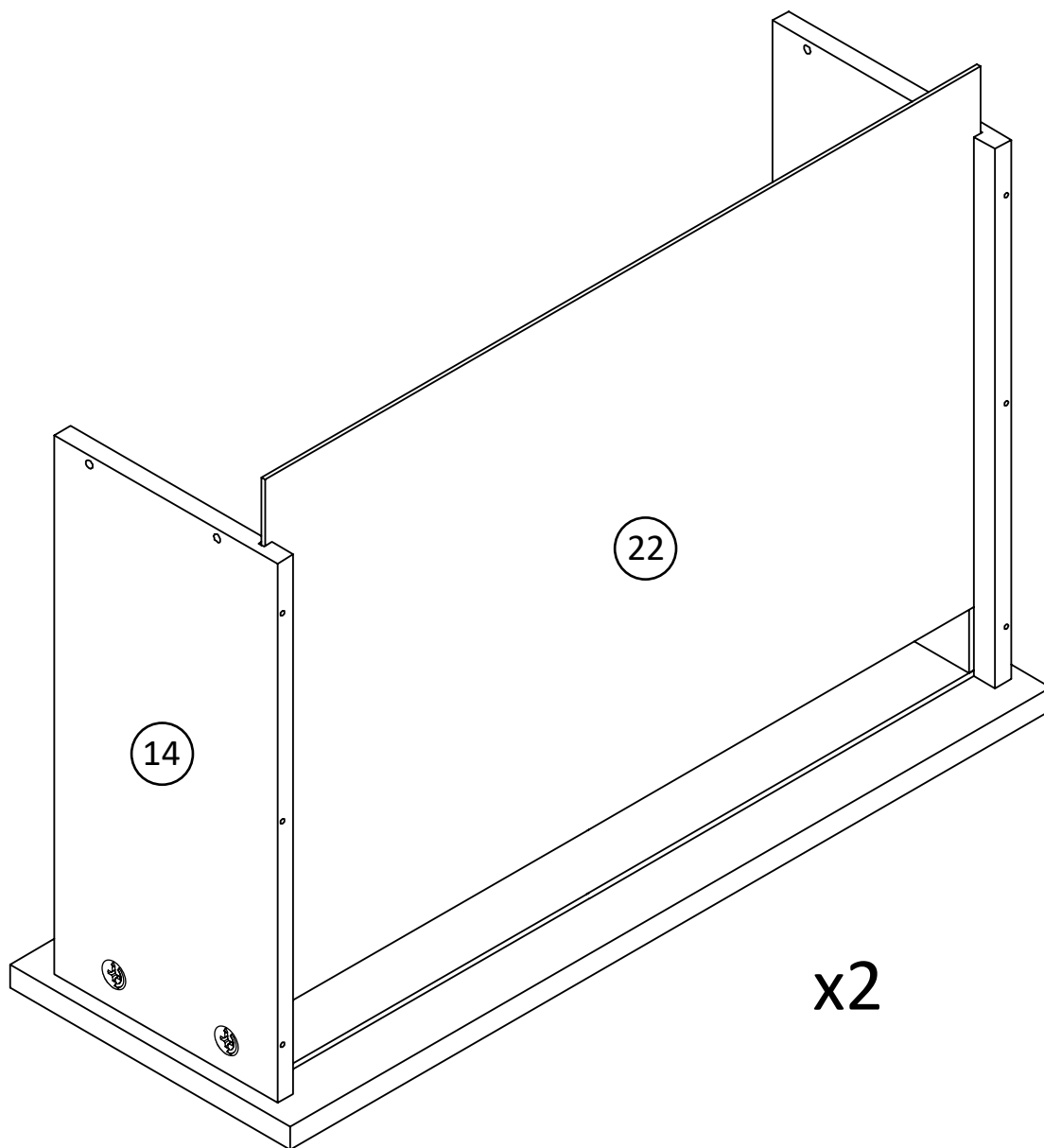

\* raw edges are shaded

# Step 16

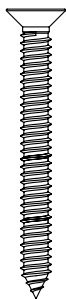
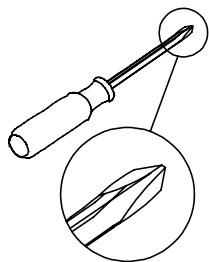

x8  
TUD0009

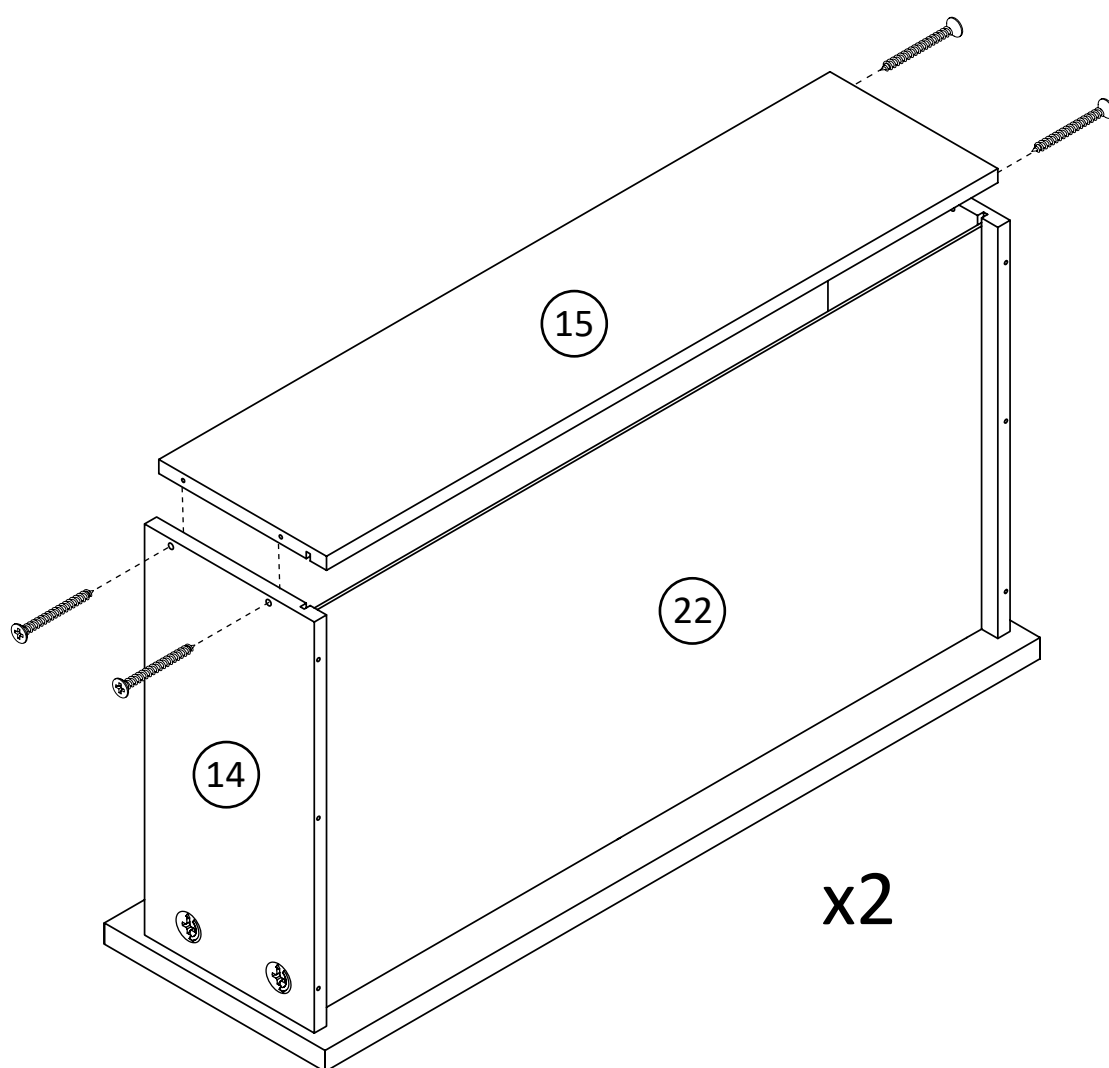

\* raw edges are shaded

# Step 17

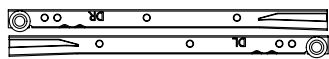
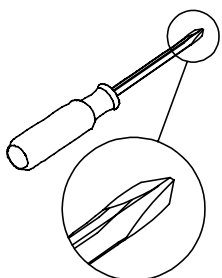

x2 SETS  
TUD0016



x12  
TUD0008

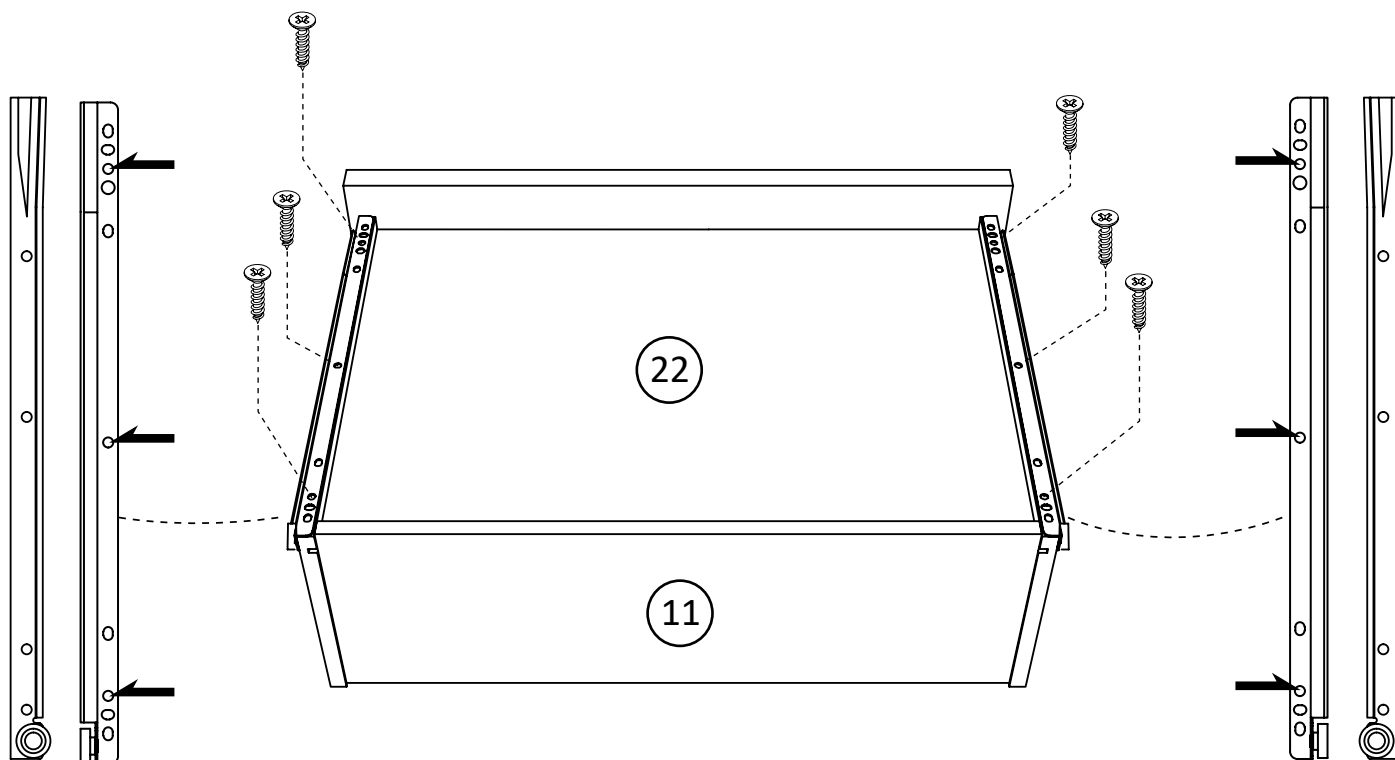

x2

\* raw edges are shaded



# Step 18

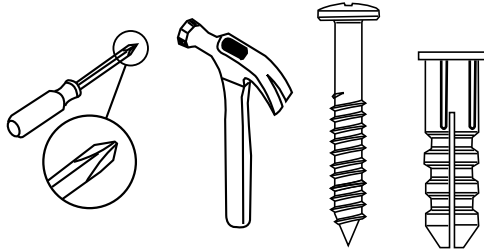

**For Masonry, Concrete, or other wall materials:**  
Consult your local hardware store for appropriate anchors to securely attach the safety bracket.

**IMPORTANT:** THIS UNIT MUST BE SECURE TO THE WALL TO HELP PREVENT TIPOVER. FOLLOW THESE INSTRUCTIONS TO INSTALL THE ANTI-TIPPING SAFETY BRACKET PROVIDED WITH THIS PRODUCT.

## WARNING

**Serious or fatal crushing injuries can occur from furniture tip over.**

**To prevent tip over:**

- \* Install tipover restraint provided
- \* place heaviest items in the lowest drawers
- \* Unless specifically designed to accommodate, do not set TVs or other heavy objects on the top of this product
- \* Never allow children to climb or hang on drawers, door, or shelves
- \* Never open more than one drawer at a time

**Use of tip over restraints may only reduce, but not eliminate the risk of tip over**

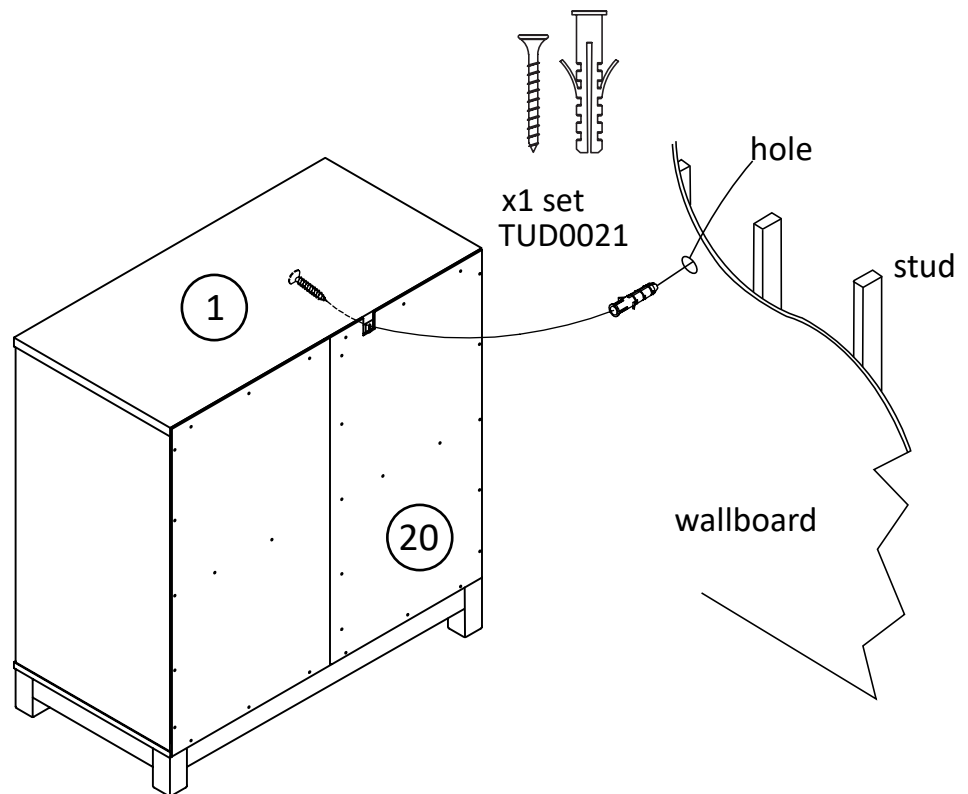

### OPTION 1: Attachment into a wall stud (preferred method)

Using a stud finder, locate a stud in the wall. Place your unit against the wall, with the safety bracket aligned in this location.

To make driving the screw easier, you can drill a 1/8" diameter pilot hole (3mm) through the safety bracket into the stud.

Drive the screw through the safety bracket into the wall stud. Tighten the screw that was not fully tightened.

### OPTION 2: Attachment into drywall

Locate your unit where desired against a wall and mark the wall through the safety bracket, then move your unit aside.

Drill a 3/16" diameter hole (5mm) into the wallboard. Tap the wall anchor into the hole until it is flush. Move your unit into location and fasten the wall bracket to the wall anchor with the screw.

Tighten the screw that was not fully tightened.

# Step 19

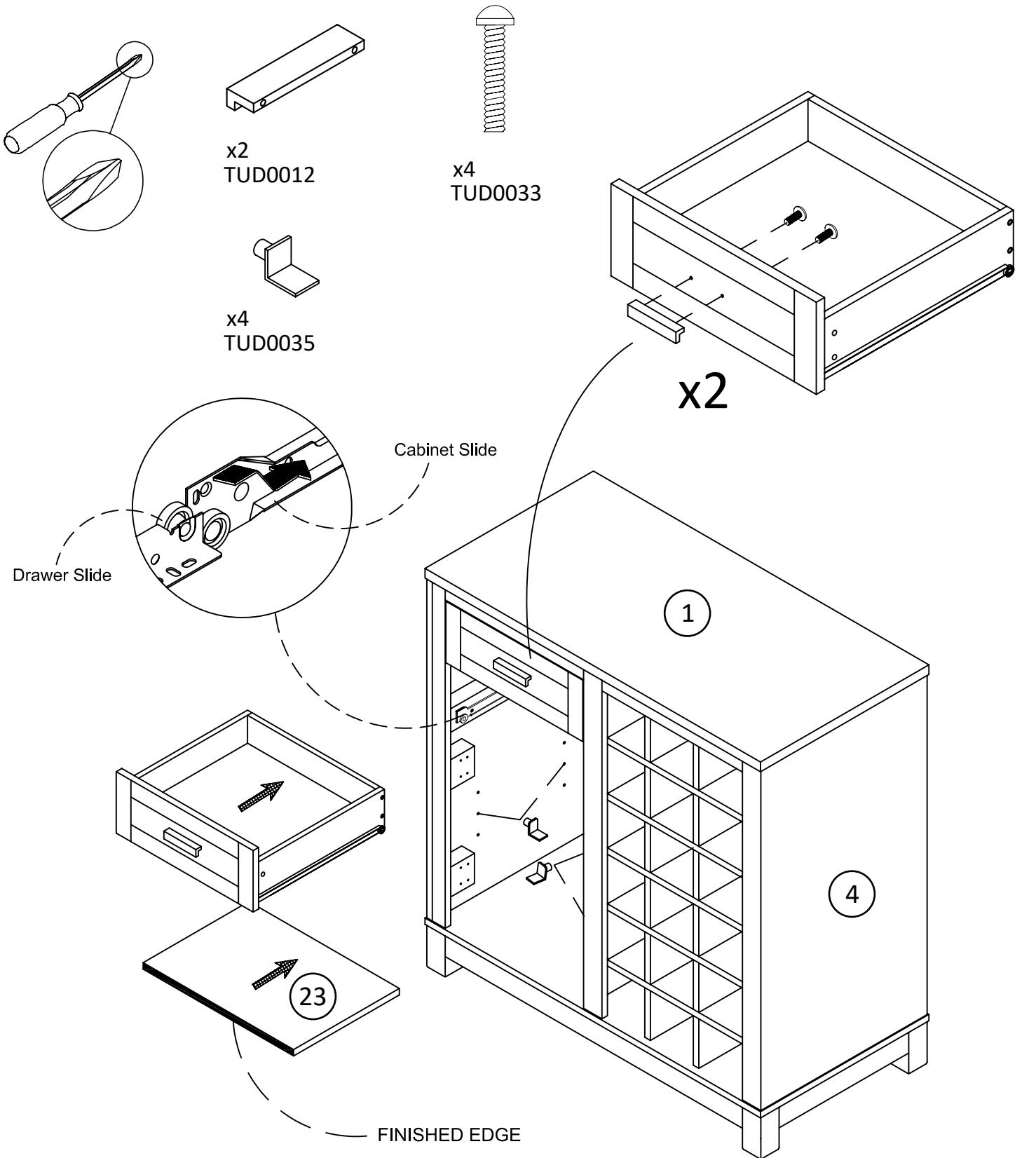

\* raw edges are shaded

# Step 20

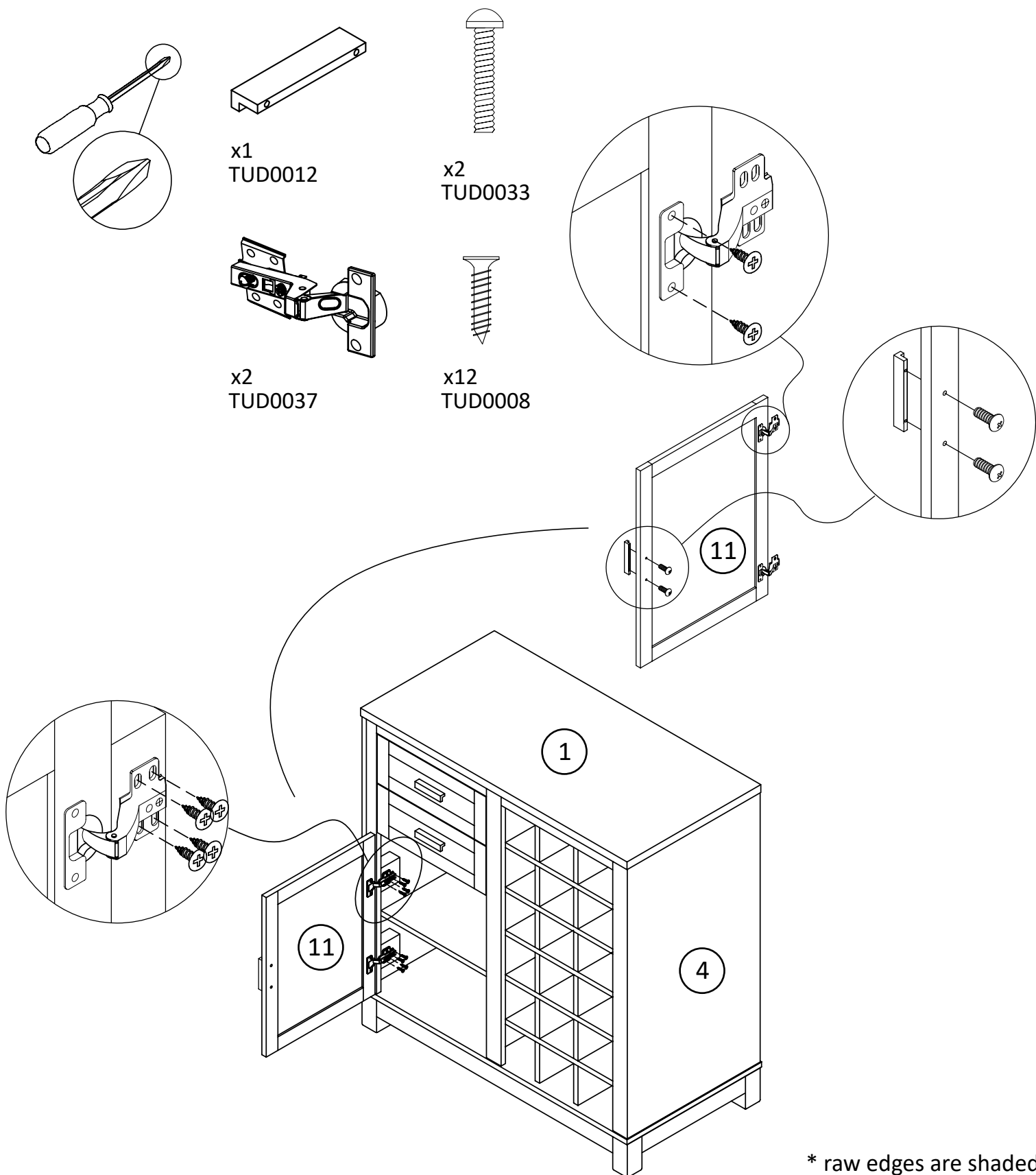

\* raw edges are shaded

# Step 21

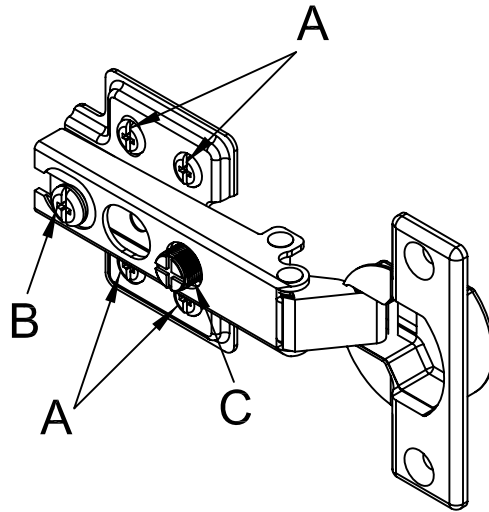

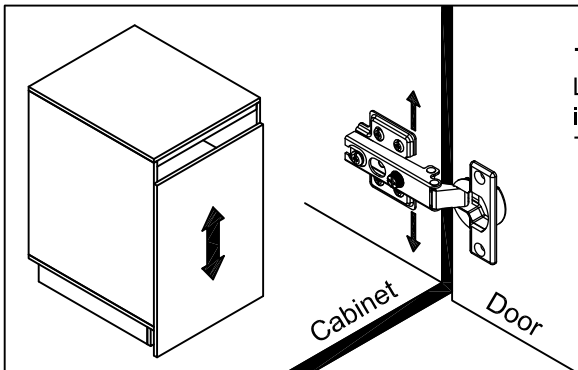
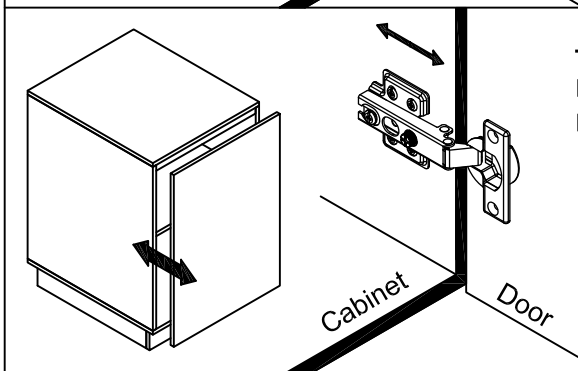
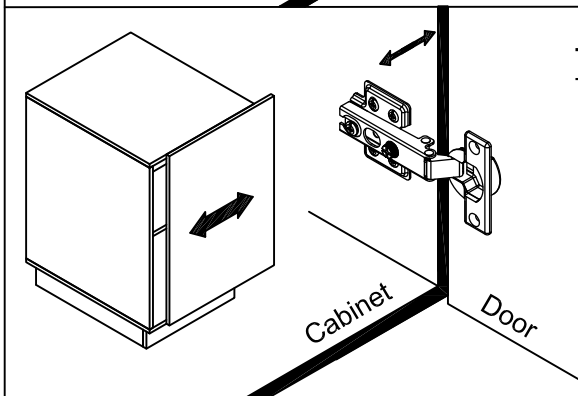
	<p><b>To adjust the vertical height.</b> Loosen the four screws "A" on both hinges. Two of them are usually in slotted holes which allows you to adjust up or down by a few mm. Then tighten back up.</p>
	<p><b>To adjust depth.</b> Loosen screw "B" and adjust door, if the door can not be adjusted, please loosen screw "C", then try again. Tighten screw "B" and "C".</p>
	<p><b>To adjust side ways.</b> Turning the screw "C" on BOTH hinges on each door.</p>

\* raw edges are shaded

## Maximum Loads

This unit has been designed to support the maximum loads shown. Exceeding these load limits could cause sagging, instability, product collapse, and/or serious injury.

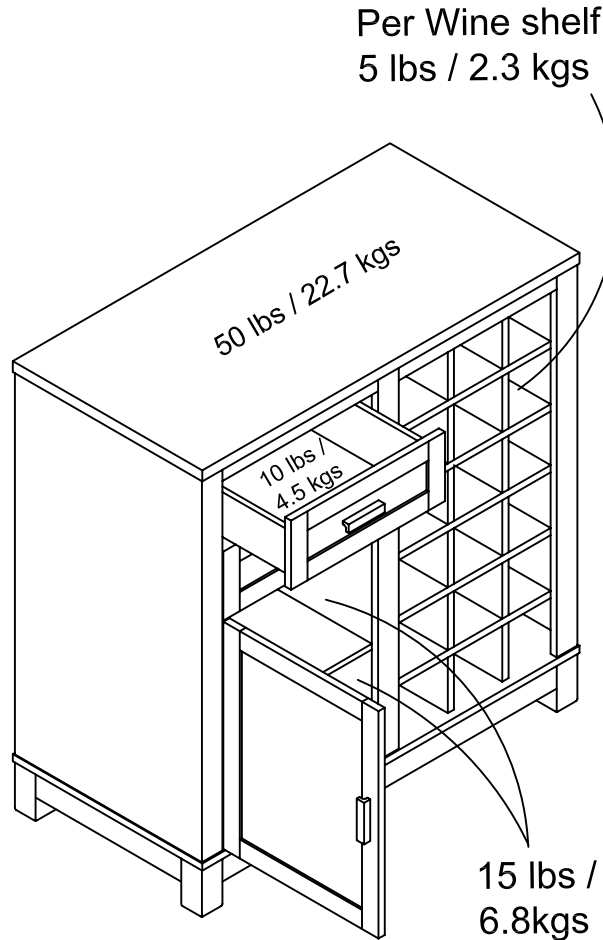

Enjoy your furniture.

**Warning: Risk of serious injury to person - do not place a television on this furniture. This furniture is not approved for use with a television.**

### Certificate of Conformity

1. This certificate applies to Dorel Home Furnishings, Inc. product identified by this instruction manual.
2. This certificate applies to compliance of this product with the CPSC Ban on Lead-Containing Paint ( 16 CFR 1303).
3. This product is distributed by: Dorel Home Furnishings, Inc.  
410 East First Street South,  
Wright City, MO 63390  
636-745-3351
4. Site of Manufacturer: Muar, Malaysia.
5. See front page of instruction manual for date of manufacturer.

## Register your product to receive the following:



- \* New trend details -sneak peek on what's new
- \* Surveys -have a voice within our community
- \* Exclusive deals and discount codes
- \* Quick and easy replacement part service

To register your product, visit [Ameriwoodhome.com](http://Ameriwoodhome.com)

## *5 Star Rating*



Visit your local retailer's website, rate your purchased product and leave us some feedback!

We would like to extend a big "Thank You" to all of our customers for taking the time to assemble this Ameriwood Home product, and to give us your valuable feedback

*Thank  
You!*



**THANK YOU for your business.**



Your feedback and 5-star review is important to us!



If you are happy with this product, please review on the site you purchased it from.



If your product has issues, please contact us so that we can fix them.

Please note, we do not have control over how shipping carriers treat our products and could cause damage to your order. If your product is damaged, please contact us for help.

**1-800-489-3351 • [Customer.service@dorel.com](mailto:Customer.service@dorel.com)  
Customer Service Hours: 9am - 5pm Central Time (CST)  
Monday through Friday**



## Cubierta Delantera

Este libro de instrucciones contiene información IMPORTANTE de seguridad. Por favor lea y manténgalo para referencia en el futuro.

No Regrese este producto! Comuníquese con nuestro amistoso equipo de servicio al cliente para obtener ayuda.

Llámenos al: 1-800-489-3351 (Gratis) Lunes - Viernes 9am - 5pm CST

Visitar: [www.ameriwoodhome.com](http://www.ameriwoodhome.com)

## PRECAUCION

Este mueble puede volcarse y causar graves heridas y/o muerte.

Anclar el mueble a un poste de madera en la pared (si esto se requiere).

No Permita que los niños monten el mueble.

Mantenga los artículos más pesados en los cajones de abajo.

## Consejos Útiles (página 2)

- Abra su artículo en el área donde usted planea utilizarlo para evitar levantar y moverlo menos
- Identificar, ordenar y contar las piezas antes de intentar ensamblar
- Las clavijas de compresión se golpean con un martillo
- Las diapositivas están marcadas con una R (derecha) y L (izquierda) para la colocación correcta
- Asegúrese de que siempre este el punto localizado en la parte superior de bloqueador de leva este volteado hacia borde exterior
- Utilizar todos los clavos para el panel de atrás y distribuirlos por igual
- El panel de atrás debe utilizarse para asegurarse de que la unidad quede fija y firme
- No use químicas fuertes ni limpiadores abrasivos en este artículo
- Nunca empuje, tire ni arrastre los muebles

## Antes de Que Empieces (página 3)

- Lea cuidadosamente cada paso y siga el orden correcto
- Separar y contar todas sus piezas y hardware
- Dése suficiente espacio para el proceso de ensamble
- Tenga las siguientes herramientas: destornillador de cabeza plana, #2 cabeza Phillips Destornillador y martillo
- Precaución: Si usa un taladro electrónico o un destornillador eléctrico para atornillar, por favor asegúrese que deje de atornillar cuando el tornillos este apretado. Fallar hacer esto puede causar barrer el tornillo

## Sistema de fijar el bloqueo de leva (página 3)

Esta sistema de fijar el bloqueo de leva sera usado en todo el proceso ensamble

## Identificación de la Junta (página 4&5)

Tamaño no real

## Lista de (página 6)

Tamaño real

## Lista de (página 7)

Tamaño no real



## Página 18

### **IMPORTANTE! EL PANEL TRASERO ES UNA PARTE ESTRUCTURAL DE ESTA UNIDAD Y DEBE INSTALARSE CORRECTAMENTE.**

Sujeta el panel trasero como se muestra clavando directamente en los bordes sin procesar.  
Asegúrese de que la unidad es cuadrada.  
La distancia de la esquina a la esquina debe ser igual a como se muestra.

## Página 25

Para mampostería, hormigón u otros materiales de pared:  
Consulte en su ferretería local los anclajes apropiados para sujetar de forma segura el soporte de seguridad.

**IMPORTANTE: ESTA UNIDAD DEBE ESTAR SEGURA EN LA PARED PARA AYUDAR A PREVENIR AL TIPOVER. SIGA ESTAS INSTRUCCIONES PARA INSTALAR EL SOPORTE DE SEGURIDAD ANTIDISCIPLINADOR PROPORCIONADO CON ESTE PRODUCTO.**

### ADVERTENCIA

Lesiones por aplastamiento graves o fatales puede ocurrir desde la punta del mueble. Para evitar volcar:

- \* Instale la restricción de vuelco provista
- \* coloque los artículos más pesados en los cajones más bajos
- \* A menos que esté específicamente diseñado para acomodar, no instale televisores u otros objetos pesados en la parte superior de este producto
- \* Nunca permita que los niños trepen o cuelguen de los cajones, puertas o estanterías
- \* Nunca abra más de un cajón a la vez

El uso de restricciones sobre volteos solo puede reducir, pero no eliminar, el riesgo de vuelco

### OPCIÓN 1: Adjunto a un montante de pared (método preferido)

Usando un buscador de pernos, ubique un perno en la pared. Coloque su unidad contra la pared, con el soporte de seguridad alineado en esta ubicación.

Para facilitar el manejo del tornillo, puede perforar un orificio piloto de 1/8 "de diámetro (3 mm) a través de la seguridad

soporte en el perno.

Introduzca el tornillo a través del soporte de seguridad en el montante de la pared. Apretar el tornillo que no estaba completamente

Tightened.

### OPCIÓN 2: fijación al panel de yeso

Ubique su unidad donde desee contra una pared y marque la pared a través del soporte de seguridad, luego mueva tu unidad a un lado.

Taladre un orificio de 3/16 "de diámetro (5 mm) en el tablero. Toque el anclaje de pared en el orificio hasta que quede al ras. Mueva su unidad a su ubicación y ajuste el soporte de pared al anclaje de pared con el tornillo.

Apriete el tornillo que no estaba completamente apretado.

## Página 28

### Para ajustar la altura vertical.

Afloje los cuatro tornillos "A" en ambas bisagras. Dos de ellos generalmente están en agujeros ranurados que le permiten ajustar hacia arriba o hacia abajo en unos pocos mm. Luego vuelve a iluminarte.

### Para captar la profundidad.

Afloje el tornillo "B" y ajuste la puerta, si la puerta no se puede ajustar, afloje el tornillo "C", luego vuelva a intentarlo. Apriete el tornillo "B" y C.

### Para ajustar las formas laterales.

Girando el tornillo "C" en AMBAS bisagras en cada puerta.

## Página 29

### ETIQUETA DE PRECAUCIÓN

#### CARGA MAXIMA

Esta unidad ha sido diseñada para soportar la carga máxima anotada. El exceder estos límites puede causar inestabilidad, colapsarse y/o causar serias lesiones.

**Advertencia: asegúrese de quitar todos los objetos antes de mover la unidad ensamblada. La unidad debe ser levantada por más de una persona, no arrastrada o empujada. No hacerlo así lo hará causar daño al producto, inestabilidad, colapso del producto y / o lesiones graves.**

## Página 30

Registre su producto para recibir lo siguiente:

- \* Nuevos detalles sobre las tendencias - Sneek echa un vistazo a lo nuevo
  - \* Encuestas - tener una voz dentro de nuestra comunidad
  - \* Ofertas exclusivas y códigos de descuento
- Servicio de piezas de repuesto rápido y fácil

Para registrar su producto, visite [Ameriwoodhome.com](http://Ameriwoodhome.com)

5 estrellas

Visite el sitio web de su distribuidor local, califique su producto comprado y déjenos algunos comentarios!

Nos gustaría extender un gran "Gracias" a todos nuestros clientes por tomarse el tiempo para montar este producto Ameriwood Home, y para darnos sus valiosos comentarios

Gracias!

**Página 31**

**Gracias por hacer negocios.**

¡Tu opinión y la de 5 estrellas es importante para nosotros!

Si está satisfecho con este producto, revise en el sitio donde lo compró.

Si su producto tiene problemas, contáctenos para que podamos solucionarlo.

Tenga en cuenta que no tenemos control sobre la forma en que los transportistas tratan nuestros productos y podrían dañar su pedido. Si su producto está dañado, póngase en contacto con nosotros para obtener ayuda.

\* raw edges are shaded

## capot avant

Ce livret d'instructions contient d'importantes informations de sécurité. S'il vous plaît lire et conserver pour référence ultérieure.

Ne pas retourner ce produit! Contactez notre équipe de service à la clientèle amical pour aider.

Appel: 1-800-489-3351 (gratuit) Lundi - Vendredi 9am - 5pm CST

Visite: [www.ameriwoodhome.com](http://www.ameriwoodhome.com)

## MISE EN GARDE

Ce mobilier peut basculer et causer des blessures graves et / ou la mort.

Ancrer les meubles à un poteau en bois sur le mur (si cela est nécessaire).

Ne laissez pas les enfants monter l'armoire.

Gardez les articles plus lourds dans les tiroirs ci-dessous.

## Conseil (page 2)

- Ouvrez votre article dans la zone où vous prévoyez de l'utiliser pour éviter de soulever et déplacer moins
- Identifier, trier et compter les pièces avant de monter
- bouchons de compression sont frappés avec un marteau
- Les lames sont marqués par un R (droite) et L (à gauche) pour le positionnement correct
- Assurez-vous toujours ce point, je Aviana sur le dessus de la came de blocage ce bord extérieur volteadohacia
- Utilisez tous les clous du panneau arrière et les distribuer également
- Le panneau arrière doit être utilisé pour faire en sorte que l'unité est fixe et ferme
- Ne pas utiliser de produits chimiques ou de produits abrasifs sur cet article
- Ne jamais pousser, tirer ou meubles de glisser

## Avant de commencer (page 3)

- Lire attentivement chaque étape et suivre l'ordre
- separate et compter toutes les pièces et matériel
- Dése un espace suffisant pour le processus d'assemblage
- Soyez les outils suivants: tournevis Phillips n ° 2 tête  
Tournevis et un marteau
- Precaución: Si vous utilisez une perceuse électronique ou un tournevis électrique à vis, s'il vous plaît faire arrêter le vissage lorsque le tonillos ce serré. Le non-respect cela peut provoquer balayer la vis

## Système de régler le verrou de came (page 3)

Ce système de fixation du verrou de came sera utilisé tout au long du processus d'assemblage

## Identification du Conseil (page 4 et 5)

pas la taille réelle

## Liste (Page 6)

taille réelle

## Liste (page 7)

pas la taille réelle

## Page 18

### **IMPORTANT! LE PANNEAU ARRIÈRE EST UNE PARTIE DE STRUCTURE ET CET APPAREIL DOIT ÊTRE INSTALLÉ CORRECTEMENT.**

En tenant le panneau arrière comme indiqué clouer directement sur les bords bruts.

Assurez-vous que l'unité est carrée.

La distance d'un coin à doit être égal comme indiqué.

## page 25

Pour la maçonnerie, le béton ou d'autres matériaux muraux:

Consultez votre quincaillier local pour obtenir les ancrages appropriés afin de fixer solidement le support de sécurité.

**IMPORTANT: CET APPAREIL DOIT ÊTRE SÉCURISÉ AU MUR POUR AIDER À PRÉVENIR TIPOVER. SUIVEZ CES INSTRUCTIONS POUR INSTALLER LE SUPPORT DE SÉCURITÉ ANTI-BASCULE FOURNI AVEC CE PRODUIT.**

### ATTENTION

Blessures graves ou fatales

peut provenir de meubles renversés. Pour éviter le basculement:

- \* Installez la retenue de renversement fournie
- \* placer les articles les plus lourds dans les tiroirs les plus bas
- \* Sauf si spécifiquement conçu pour accommoder, ne pas placer les téléviseurs ou autres objets lourds sur le dessus de ce produit
- \* Ne laissez jamais les enfants grimper ou pendre sur des tiroirs, des portes ou des étagères
- \* N'ouvrez jamais plus d'un tiroir à la fois

L'utilisation de dispositifs de retenue peut uniquement réduire, mais non éliminer, le risque de basculement

#### OPTION 1: Fixation dans un montant mural (méthode préférée)

À l'aide d'un détecteur de goujons, localisez un goujon dans le mur. Placez votre appareil contre le mur, avec le support de sécurité aligné à cet endroit.

Pour faciliter la conduite de la vis, vous pouvez percer un trou pilote de 3 mm support dans le goujon.

Faites passer la vis à travers le support de sécurité dans le poteau mural. Serrer la vis qui n'était pas complètement serré.

#### OPTION 2: Fixation dans les cloisons sèches

Placez votre appareil là où vous le souhaitez contre un mur et marquez le mur à travers le support de sécurité, puis

déplacez votre unité de côté.

Percez un trou de 5 mm de diamètre dans le panneau mural. Appuyez sur l'ancrage mural dans le trou jusqu'à ce qu'il affleure. Placez votre appareil en place et fixez le support mural à l'ancrage mural à l'aide de la vis.

Serrer la vis qui n'a pas été complètement serrée.

## page 28

### **Pour ajuster la hauteur verticale.**

Desserrez les quatre vis "A" sur les deux charnières. Deux d'entre eux sont généralement dans des trous oblongs qui vous permettent de régler de quelques millimètres vers le haut ou vers le bas. Puis alléger.

### **Ackust profondeur.**

Desserrer la vis "B" et ajuster la porte, si la porte ne peut pas être ajustée, desserrer la vis "C.", puis réessayer. Visser les vis "B" et C.

### **Pour régler les côtés.**

Tourner la vis "C" sur les deux charnières de chaque porte.

## Page 29

### MISE EN GARDE

#### MAXIMUM DE CHARGE

Cet appareil est conçu pour supporter la charge maximale enregistrée. Le dépassement de ces limites peut provoquer l'instabilité, l'effondrement et / ou causer des blessures graves.

**Avertissement: Veuillez vous assurer que tous les objets sont retirés avant de déplacer l'unité assemblée. L'unité doit être soulevée par plus d'une personne, non traînée ou poussée. Ne pas le faire causer des dommages au produit, l'instabilité, l'effondrement du produit et / ou des blessures graves.**

## Page 30

Enregistrez votre produit pour recevoir les éléments suivants:

- \* De nouveaux détails sur les tendances - Sneek vérifier la nouvelle
  - \* Sondages - ont une voix dans notre communauté
  - \* Offres exclusives et des codes de réduction
- Service de pièces de rechange rapide et facile

Pour enregistrer votre produit, visitez [Ameriwoodhome.com](http://Ameriwoodhome.com)

5 étoiles

Visitez le site Web de votre distributeur local, classez votre produit acheté et laissez des commentaires!

Nous aimerions étendre un grand "Merci" à tous nos clients pour prendre le temps de rassembler ce produit Ameriwood Home et de nous faire part de vos précieux commentaires

Merci!

Page 31

**MERCI pour votre entreprise.**

Vos commentaires et vos commentaires 5 étoiles sont importants pour nous!

Si vous êtes satisfait de ce produit, veuillez consulter le site sur lequel vous l'avez acheté.

Si votre produit a des problèmes, veuillez nous contacter afin que nous puissions les résoudre.

Veillez noter que nous n'avons aucun contrôle sur la manière dont les transporteurs maritimes traitent nos produits et pourraient endommager votre commande Si votre produit est endommagé, veuillez nous contacter pour obtenir de l'aide.

\* raw edges are shaded